

KEITHLEY

KPCI-3160

PCI Bus Digital I/O Board

User's Manual

A GREATER MEASURE OF CONFIDENCE

WARRANTY

Hardware

Keithley Instruments, Inc. warrants that, for a period of three (3) years from the date of shipment, the Keithley Hardware product will be free from defects in materials or workmanship. This warranty will be honored provided the defect has not been caused by use of the Keithley Hardware not in accordance with the instructions for the product. This warranty shall be null and void upon: (1) any modification of Keithley Hardware that is made by other than Keithley and not approved in writing by Keithley or (2) operation of the Keithley Hardware outside of the environmental specifications therefore.

Upon receiving notification of a defect in the Keithley Hardware during the warranty period, Keithley will, at its option, either repair or replace such Keithley Hardware. During the first ninety days of the warranty period, Keithley will, at its option, supply the necessary on site labor to return the product to the condition prior to the notification of a defect. Failure to notify Keithley of a defect during the warranty shall relieve Keithley of its obligations and liabilities under this warranty.

Other Hardware

The portion of the product that is not manufactured by Keithley (Other Hardware) shall not be covered by this warranty, and Keithley shall have no duty of obligation to enforce any manufacturers' warranties on behalf of the customer. On those other manufacturers' products that Keithley purchases for resale, Keithley shall have no duty of obligation to enforce any manufacturers' warranties on behalf of the customer.

Software

Keithley warrants that for a period of one (1) year from date of shipment, the Keithley produced portion of the software or firmware (Keithley Software) will conform in all material respects with the published specifications provided such Keithley Software is used on the product for which it is intended and otherwise in accordance with the instructions therefore. Keithley does not warrant that operation of the Keithley Software will be uninterrupted or error-free and/or that the Keithley Software will be adequate for the customer's intended application and/or use. This warranty shall be null and void upon any modification of the Keithley Software that is made by other than Keithley and not approved in writing by Keithley.

If Keithley receives notification of a Keithley Software nonconformity that is covered by this warranty during the warranty period, Keithley will review the conditions described in such notice. Such notice must state the published specification(s) to which the Keithley Software fails to conform and the manner in which the Keithley Software fails to conform to such published specification(s) with sufficient specificity to permit Keithley to correct such nonconformity. If Keithley determines that the Keithley Software does not conform with the published specifications, Keithley will, at its option, provide either the programming services necessary to correct such nonconformity or develop a program change to bypass such nonconformity in the Keithley Software. Failure to notify Keithley of a nonconformity during the warranty shall relieve Keithley of its obligations and liabilities under this warranty.

Other Software

OEM software that is not produced by Keithley (Other Software) shall not be covered by this warranty, and Keithley shall have no duty or obligation to enforce any OEM's warranties on behalf of the customer.

Other Items

Keithley warrants the following items for 90 days from the date of shipment: probes, cables, rechargeable batteries, diskettes, and documentation.

Items not Covered under Warranty

This warranty does not apply to fuses, non-rechargeable batteries, damage from battery leakage, or problems arising from normal wear or failure to follow instructions.

Limitation of Warranty

This warranty does not apply to defects resulting from product modification made by Purchaser without Keithley's express written consent, or by misuse of any product or part.

Disclaimer of Warranties

EXCEPT FOR THE EXPRESS WARRANTIES ABOVE KEITHLEY DISCLAIMS ALL OTHER WARRANTIES, EXPRESS OR IMPLIED, INCLUDING WITHOUT LIMITATION, ALL IMPLIED WARRANTIES OF MERCHANTABILITY AND FITNESS FOR A PARTICULAR PURPOSE. KEITHLEY DISCLAIMS ALL WARRANTIES WITH RESPECT TO THE OTHER HARDWARE AND OTHER SOFTWARE.

Limitation of Liability

KEITHLEY INSTRUMENTS SHALL IN NO EVENT, REGARDLESS OF CAUSE, ASSUME RESPONSIBILITY FOR OR BE LIABLE FOR: (1) ECONOMICAL, INCIDENTAL, CONSEQUENTIAL, INDIRECT, SPECIAL, PUNITIVE OR EXEMPLARY DAMAGES, WHETHER CLAIMED UNDER CONTRACT, TORT OR ANY OTHER LEGAL THEORY, (2) LOSS OF OR DAMAGE TO THE CUSTOMER'S DATA OR PROGRAMMING, OR (3) PENALTIES OR PENALTY CLAUSES OF ANY DESCRIPTION OR INDEMNIFICATION OF THE CUSTOMER OR OTHERS FOR COSTS, DAMAGES, OR EXPENSES RELATED TO THE GOODS OR SERVICES PROVIDED UNDER THIS WARRANTY.



Keithley Instruments, Inc. 28775 Aurora Road • Cleveland, Ohio 44139 • 440-248-0400 • Fax: 440-248-6168
1-888-KEITHLEY (534-8453) • www.keithley.com

Sales Offices: BELGIUM: Bergensesteenweg 709 • B-1600 Sint-Pieters-Leeuw • 02-363 00 40 • Fax: 02/363 00 64
CHINA: Yuan Chen Xin Building, Room 705 • 12 Yumin Road, Dewai, Madian • Beijing 100029 • 8610-6202-2886 • Fax: 8610-6202-2892
FINLAND: Tietäjantie 2 • 02130 Espoo • Phone: 09-54 75 08 10 • Fax: 09-25 10 51 00
FRANCE: 3, allée des Garays • 91127 Palaiseau Cédex • 01-64 53 20 20 • Fax: 01-60 11 77 26
GERMANY: Landsberger Strasse 65 • 82110 Germering • 089/84 93 07-40 • Fax: 089/84 93 07-34
GREAT BRITAIN: Unit 2 Commerce Park, Brunel Road • Theale • Berkshire RG7 4AB • 0118 929 7500 • Fax: 0118 929 7519
INDIA: Flat 2B, Willocrissa • 14, Rest House Crescent • Bangalore 560 001 • 91-80-509-1320/21 • Fax: 91-80-509-1322
ITALY: Viale San Gimignano, 38 • 20146 Milano • 02-48 39 16 01 • Fax: 02-48 30 22 74
JAPAN: New Pier Takeshiba North Tower 13F • 11-1, Kaigan 1-chome • Minato-ku, Tokyo 105-0022 • 81-3-5733-7555 • Fax: 81-3-5733-7556
KOREA: 2FL., URI Building • 2-14 Yangjae-Dong • Seocho-Gu, Seoul 137-888 • 82-2-574-7778 • Fax: 82-2-574-7838
NETHERLANDS: Postbus 559 • 4200 AN Gorinchem • 0183-635333 • Fax: 0183-630821
SWEDEN: c/o Regus Business Centre • Frosundaviks Allé 15, 4tr • 169 70 Solna • 08-509 04 679 • Fax: 08-655 26 10
SWITZERLAND: Kriesbachstrasse 4 • 8600 Dübendorf • 01-821 94 44 • Fax: 01-820 30 81
TAIWAN: 1FL., 85 Po Ai Street • Hsinchu, Taiwan, R.O.C. • 886-3-572-9077 • Fax: 886-3-572-9031

KPCI-3160
PCI Bus Digital I/O Board
User's Manual

Windows and WindowsNT are registered trademarks of Microsoft Corporation.
DriverLINX is a registered trademark of Scientific Software Tools, Inc.

©1999, Keithley Instruments, Inc.
All rights reserved.
Cleveland, Ohio, U.S.A.
Fourth Printing, February 2001
Document Number: 98110 Rev. D

Manual Print History

The print history shown below lists the printing dates of all Revisions and Addenda created for this manual. The Revision Level letter increases alphabetically as the manual undergoes subsequent updates. Addenda, which are released between Revisions, contain important change information that the user should incorporate immediately into the manual. Addenda are numbered sequentially. When a new Revision is created, all Addenda associated with the previous Revision of the manual are incorporated into the new Revision of the manual. Each new Revision includes a revised copy of this print history page.

Revision A (Document Number 98110)	December 1999
Revision B (Document Number 98110)	May 2000
Revision C (Document Number 98110)	August 2000
Revision D (Document Number 98110)	February 2001

The following safety precautions should be observed before using this product and any associated instrumentation. Although some instruments and accessories would normally be used with non-hazardous voltages, there are situations where hazardous conditions may be present.

This product is intended for use by qualified personnel who recognize shock hazards and are familiar with the safety precautions required to avoid possible injury. Read and follow all installation, operation, and maintenance information carefully before using the product. Refer to the manual for complete product specifications.

If the product is used in a manner not specified, the protection provided by the product may be impaired.

The types of product users are:

Responsible body is the individual or group responsible for the use and maintenance of equipment, for ensuring that the equipment is operated within its specifications and operating limits, and for ensuring that operators are adequately trained.

Operators use the product for its intended function. They must be trained in electrical safety procedures and proper use of the instrument. They must be protected from electric shock and contact with hazardous live circuits.

Maintenance personnel perform routine procedures on the product to keep it operating properly, for example, setting the line voltage or replacing consumable materials. Maintenance procedures are described in the manual. The procedures explicitly state if the operator may perform them. Otherwise, they should be performed only by service personnel.

Service personnel are trained to work on live circuits, and perform safe installations and repairs of products. Only properly trained service personnel may perform installation and service procedures.

Keithley products are designed for use with electrical signals that are rated Installation Category I and Installation Category II, as described in the International Electrotechnical Commission (IEC) Standard IEC 60664. Most measurement, control, and data I/O signals are Installation Category I and must not be directly connected to mains voltage or to voltage sources with high transient over-voltages. Installation Category II connections require protection for high transient over-voltages often associated with local AC mains connections. Assume all measurement, control, and data I/O connections are for connection to Category I sources unless otherwise marked or described in the Manual.

Exercise extreme caution when a shock hazard is present. Lethal voltage may be present on cable connector jacks or test fixtures. The American National Standards Institute (ANSI) states that a shock hazard exists when voltage levels greater than 30V RMS, 42.4V peak, or 60VDC are present. **A good safety practice is to expect that hazardous voltage is present in any unknown circuit before measuring.**

Operators of this product must be protected from electric shock at all times. The responsible body must ensure that operators are prevented access and/or insulated from every connection point. In some cases, connections must be exposed to potential human contact. Product operators in these circumstances must be trained to protect themselves from the risk of electric shock. If the circuit is capable of operating at or above 1000 volts, **no conductive part of the circuit may be exposed.**

Do not connect switching cards directly to unlimited power circuits. They are intended to be used with impedance limited sources. NEVER connect switching cards directly to AC mains. When connecting sources to switching cards, install protective devices to limit fault current and voltage to the card.

Before operating an instrument, make sure the line cord is connected to a properly grounded power receptacle. Inspect the connecting cables, test leads, and jumpers for possible wear, cracks, or breaks before each use.

When installing equipment where access to the main power cord is restricted, such as rack mounting, a separate main input power disconnect device must be provided, in close proximity to the equipment and within easy reach of the operator.

For maximum safety, do not touch the product, test cables, or any other instruments while power is applied to the circuit under test. ALWAYS remove power from the entire test system and discharge any capacitors before: connecting or disconnecting cables or jumpers, installing or removing switching cards, or making internal changes, such as installing or removing jumpers.

Do not touch any object that could provide a current path to the common side of the circuit under test or power line (earth) ground. Always make measurements with dry hands while standing on a dry, insulated surface capable of withstanding the voltage being measured.



The instrument and accessories must be used in accordance with its specifications and operating instructions or the safety of the equipment may be impaired.

Do not exceed the maximum signal levels of the instruments and accessories, as defined in the specifications and operating information, and as shown on the instrument or test fixture panels, or switching card.

When fuses are used in a product, replace with same type and rating for continued protection against fire hazard.

Chassis connections must only be used as shield connections for measuring circuits, NOT as safety earth ground connections.

If you are using a test fixture, keep the lid closed while power is applied to the device under test. Safe operation requires the use of a lid interlock.

If  or  is present, connect it to safety earth ground using the wire recommended in the user documentation.

The  symbol on an instrument indicates that the user should refer to the operating instructions located in the manual.

The  symbol on an instrument shows that it can source or measure 1000 volts or more, including the combined effect of normal and common mode voltages. Use standard safety precautions to avoid personal contact with these voltages.

The **WARNING** heading in a manual explains dangers that might result in personal injury or death. Always read the associated information very carefully before performing the indicated procedure.

The **CAUTION** heading in a manual explains hazards that could damage the instrument. Such damage may invalidate the warranty.

Instrumentation and accessories shall not be connected to humans.

Before performing any maintenance, disconnect the line cord and all test cables.

To maintain protection from electric shock and fire, replacement components in mains circuits, including the power transformer, test leads, and input jacks, must be purchased from Keithley Instruments. Standard fuses, with applicable national safety approvals, may be used if the rating and type are the same. Other components that are not safety related may be purchased from other suppliers as long as they are equivalent to the original component. (Note that selected parts should be purchased only through Keithley Instruments to maintain accuracy and functionality of the product.) If you are unsure about the applicability of a replacement component, call a Keithley Instruments office for information.

To clean an instrument, use a damp cloth or mild, water based cleaner. Clean the exterior of the instrument only. Do not apply cleaner directly to the instrument or allow liquids to enter or spill on the instrument. Products that consist of a circuit board with no case or chassis (e.g., data acquisition board for installation into a computer) should never require cleaning if handled according to instructions. If the board becomes contaminated and operation is affected, the board should be returned to the factory for proper cleaning/servicing.

Table of Contents

1 Overview

How the manual is organized	1-2
How to distinguish special text items	1-2
How to move around the electronic version of the manual	1-3

2 General Description

Specifications	2-2
System requirements	2-2
Functional description	2-2
Standard digital I/O emulation	2-2
Other I/O characteristics	2-3
Software	2-3

3 Installation

Installing the software	3-2
Software options	3-2
Installing DriverLINX	3-3
Installing application software and drivers	3-4
Installing the KPCI-3160 board	3-4
Configuring and checking the board and DriverLINX installations	3-6
Configuring the combined board and DriverLINX installations	3-6
Checking the combined board and DriverLINX installations	3-6
Connecting the KPCI-3160 board	3-7
Identifying I/O connector pin assignments on the KPCI-3160 I/O connector	3-8
Connecting interface accessories	3-10
Wiring I/O to your external circuits	3-17

4 External Interrupts

External interrupt description	4-2
External interrupt application	4-3

5 Troubleshooting

Identifying symptoms and possible causes	5-2
Systematic problem isolation	5-3
General problem isolation procedure	5-3
Specified tests	5-11
Checking for board as a PCI resource	5-11
I/O bit tests	5-12
Technical support	5-26

A Specifications

B I/O Address Mapping

General PCI address assignments	B-2
Register assignments	B-3
Control and data registers	B-3
Interrupt control/status register	B-5
Manipulating control and data registers	B-8
General approach to manipulating control and data registers	B-8
Using existing port I/O software to manipulate control and data registers	B-9

C Glossary

List of Illustrations

3 Installation

Figure 3-1	Pin assignments for the KPCI-3160 I/O connector (P101)	3-8
Figure 3-2	Connector locations on the KPIC-3160 board	3-9
Figure 3-3	The CONN-3160-D1 accessory	3-10
Figure 3-4	Using additional accessories with the KPCI-3160	3-16
Figure 3-5	Contact-closure monitoring at a KPCI-3160 board input	3-17
Figure 3-6	De-bounce circuit for an input of a KPCI-3160 board	3-17

5 Troubleshooting

Figure 5-1	Problem isolation flowchart	5-4
Figure 5-2	Mating connector wiring for loop-back test	5-14
Figure 5-3	An AIO Panel example	5-16
Figure 5-4	DIO channel tab example	5-17
Figure 5-5	Configuring the digital I/O channels as inputs and outputs	5-19
Figure 5-6	Configuring channel 0 for output bit pattern A	5-19
Figure 5-7	Proper response of channel 1 input bits when channel 0 output bits are set to bit pattern A	5-19
Figure 5-8	Proper response of channel 2 input bits when channel 0 output bits are set to bit pattern A	5-20
Figure 5-9	Configuring channel 0 for output bit pattern B	5-20
Figure 5-10	Proper response of channel 1 bits when channel 0 output bits are set to bit pattern B	5-20
Figure 5-11	Proper response of channel 2 bits when channel 0 output bits are set to bit pattern B	5-21
Figure 5-12	An AIO Panel example	5-23
Figure 5-13	Configuring the digital I/O channels as inputs and outputs	5-24
Figure 5-14	Configuring channel 0 for output bit pattern A	5-24
Figure 5-15	Configuring channel 1 for output bit pattern B	5-25

List of Tables

2 General Description

Table 2-1	System requirements	2-2
-----------	---------------------------	-----

3 Installation

Table 3-1	Pin descriptions for KPCI-3160 I/O connector (P101)	3-9
Table 3-2	Port-group 0 pin-to-pin correspondence between CONN-3160-D1 50-pin and 100-pin connectors, STP-100U 100-pin connector, and the KPCI-3160 I/O connector	3-11
Table 3-3	Port-group 1 pin-to-pin correspondence between CONN-3160-D1 50-pin and 100-pin connectors, STP-100U 100-pin connector, and the KPCI-3160 I/O connector	3-13
Table 3-4	Port-group 2 pin-to-pin correspondence between CONN-3160-D1 50-pin and 100-pin connectors, STP-100U 100-pin connector, and the KPCI-3160 I/O connector	3-14
Table 3-5	Port-group 3 pin-to-pin correspondence between CONN-3160-D1 50-pin and 100-pin connectors, STP-100U 100-pin connector, and the KPCI-3160 I/O connector	3-15
Table 3-6	Description of manufactured cables and accessories	3-16

4 External Interrupts

Table 4-1	Connector pins used for external interrupt function	4-2
Table 4-2	External-interrupt responses	4-4

5 Troubleshooting

Table 5-1	Basic troubleshooting information	5-2
Table 5-2	Loop-back connection summary	5-13
Table 5-3	Where to insert the loop-back connector	5-15
Table 5-4	Channel information	5-17
Table 5-5	Where to insert the output-set-test accessories	5-22
Table 5-6	Which channel tab to click	5-23

B I/O Address Mapping

Table B-1	Data and control register addresses	B-4
Table B-2	Control register bit functions for each port group	B-4
Table B-3	Bit functions for interrupt control/status register	B-5

1

Overview

This manual contains descriptive information and installation and use instructions for the KPCI-3160 digital interface board.

The manual is intended for data acquisition system designers, engineers, technicians, scientists, and other users responsible for setting up, cabling, and wiring signals to KPCI-3160 boards. To follow the information and instructions contained in this manual, you must be familiar with the operation of Windows 95, 98, or NT, with basic data-acquisition principles, and with your application. However, if you find unfamiliar terms in this manual, check the [Glossary](#) in [Appendix C](#). To locate topics discussed in this manual, search the index.

To use this manual effectively, review the remaining brief topics in this preface:

- The organization of the manual.
- The special font/typeface conventions used in the manual.
- Moving quickly to cross-referenced parts of the manual (in the electronic [PDF] version).

How the manual is organized

In addition to this Overview, the KPCI-3160 User's Manual is organized as follows:

- [Section 2](#) briefly describes features and characteristics of the KPCI-3160.
- [Section 3](#) first describes software options and installation notes and then the following operations (which must be done after the software is installed):
 - Installing the board.
 - Configuring the combined board and software installations.
 - Checking the combined board and software installation.
 - Installing accessories, and connecting signals.
- [Section 4](#) briefly describes the ability to configure two of the I/O lines as external interrupt enable and external interrupt request lines and identifies the connector pins used.
- [Section 5](#) describes how to troubleshoot your system and obtain technical support.
- [Appendix A](#) contains KPCI-3160 specifications.
- [Appendix B](#) describes memory-mapping information for special situations. You normally can skip [Appendix B](#). Use the DriverLINX driver provided with your board for virtually all programming situations.
- [Appendix C](#) is a glossary of some terms used in this manual.
- An [Index](#) completes the manual.

How to distinguish special text items

Italic, bold, and upper-case letters, the Courier font, and quotation marks distinguish certain text items from the general text. The following text conventions are used (exclusive of headings):

- **10 point Times Bold** distinguishes the following:
 - All Windows 95/98/NT user-interaction items: commands, screen messages, menu names, menu options, and dialog-box items—including captions, user selections, and typed user inputs (but not including dialog box names, which are in regular text).
 - **CAUTION** statements.

- *10 point Times Italic* distinguishes the following:
 - Emphasis in general.
 - Cross-references to other documents, such as other manuals or books.
 - *NOTE* statements.
- 10 POINT TIMES UPPER CASE distinguishes the following:
 - Switches, such as ON and OFF.
 - Keyboard keys, such as ENTER.
- 10 point Courier distinguishes software code statements
- “Double quote marks” distinguish the following:
 - Cross references to other manual sections, such as “[Troubleshooting](#).”
 - Literals, such as when referring to the “5V” labels on I/O connectors.

How to move around the electronic version of the manual

When reading the electronic PDF version of this manual, use Acrobat Reader **View** and **Tools** menu selections to move generally through the manual. Additionally, mouse-click on special links in the manual to jump directly to the page of a referenced item, as follows:

- Mouse-click the top margin of any page to jump to the [Table of Contents](#).
- Mouse-click on any Index or Table of Contents (TOC) page number to jump to the page.
- Mouse-click on any of these cross references to jump to the cross-referenced figure, table, section, or subsection. Cross references are not framed in red—in contrast to page numbers in the Index and Table of Contents.
 - Figure number headings, such as [Figure 3-1](#).
 - Table number headings, such as [Table 3-1](#).
 - Section and subsection headings that are enclosed in quotes, such as “[How the manual is organized](#).”

To *return* from the referenced item to what you were reading *before* you jumped to the referenced item—the Index, TOC, top page margin, or cross reference—do either of the following:

- Hold down the CONTROL key and press the [-] key (i.e. press CONTROL + -).
- In the Acrobat Reader **View** menu, click **Go Back**.

2

General Description

Specifications

General specifications are listed in “Specifications,” Appendix A. I/O connections are identified in Section 3, and I/O addresses (needed by advanced programmers, only) are defined in “I/O Address Mapping,” Appendix B.

System requirements

The system capabilities required to run the KPCI-3160 board, and to use the DriverLINX software supplied with the board, are listed in Table 2-1.

Table 2-1
System requirements

CPU Type	Pentium or higher processor on motherboard with PCI bus version 2.1.
Operating System	Windows® 95 or higher. Windows® NT version 4.0 or higher.
Memory	16 MB or greater RAM when running Windows® 95 or 98. 32 MB or greater RAM when running Windows® NT.
Hard Disk Space	4 MB for minimum installation. 50 MB for maximum installation.
Other	A CD ROM drive*. A free PCI bus expansion slot. Enough reserve computer power supply capacity to power the KPCI-3160 board, which draws 15W maximum at 5VDC.

*Any CD ROM drive that came installed with the required computer should be satisfactory. However, if you have post-installed an older CD-ROM drive or arrived at your present system by updating the microprocessor or replacing the motherboard, be aware that some early CD-ROM drives do not support the long file names often used in 32-bit Windows files.

Functional description

The KPCI-3160 is a 96-bit parallel digital interface board designed for the PCI bus. The KPCI-3160 works in a Windows 95/98/NT environment and takes advantage of the 32-bit width. Applications include communicating with peripherals, operating Keithley relay boards, and reading switch inputs. All I/O lines are TTL compatible.

Standard digital I/O emulation

The 96 I/O lines emulate the I/O lines of four Intel 8255 Programmable Peripheral Interface (PPI) chips configured for control register mode 0, as follows:

- For each emulated 8255 chip there is a PA port, a PB port, and a PC port.
- Each PA and PB port is byte-wide (8-bits) and can be set independently under software control as inputs or outputs.

- Each PC port is byte-wide but can be divided into two separate 4-bit ports: PC lower and PC upper, each of which can be set up as either inputs or outputs.

Under Windows 95/98, most existing port I/O application programs and data acquisition packages designed for ISA boards work with the KPCI-3160 board. The PCI-BIOS-assigned base address is entered in place of a user-assigned base address. (Use of such programs under Windows NT, not recommended, is much more involved.) Refer to “Using existing port I/O software to manipulate control and data registers,” Appendix B.

Other I/O characteristics

Additional I/O port characteristics are summarized below:

- Two of the KPCI-3160 general-purpose I/O lines can be alternatively configured via software to be external interrupt enable input, $\overline{\text{INT_ENN}}$, and external interrupt request input, INT_REQ.
- The KPCI-3160 can output higher currents than the industry standard 8255 chip. Output current capabilities of 15mA (source) and 64mA (sink) allow it to control many LEDs, up to 22 modules, and Keithley relay boards.

NOTE *The maximum current on each +5V and digital ground pin is 1A, limiting the total current to 2A.*

- The PA, PB, and PC ports can always be read-accessed, regardless of the direction they were initially configured for, without the external signal level being affected. For example, when a port is configured as an output, it is still possible to execute a read of that port. The data returned by the read is the data in the I/O register.
- On power-up or whenever the computer's hardware reset line is asserted, all ports are cleared and set as inputs, and interrupts are configured to start on the rising edge of the interrupt request signal (default configuration).
- The four groups of PA, PB, and PC ports interface to user I/O connections via a standard 100-pin connector. Using a CONN-3160-D1 accessory, the KPCI-3160 board can be connected to the same I/O accessories as can the KPCI-PIO96 and PIO-96J boards.
- Five volt power from the computer power supply is made available at the I/O connector, for use in external circuits.

Software

The user can select a fully integrated data acquisition software package (e.g., TestPoint or LabVIEW) or write a custom program supported by DriverLINX. DriverLINX software is included with the hardware.

DriverLINX supports programmers who wish to create custom applications using Visual C/C++, Visual Basic, or Delphi. DriverLINX accomplishes foreground and background tasks to perform data acquisition. TestPoint is a fully featured, integrated application package with a graphical drag-and-drop interface, which can be used to create data acquisition applications without programming. LabVIEW is a fully featured graphical programming language used to create virtual instrumentation.

Refer to Section 3, “Installation,” for more information about software.

3

Installation

Section 3 describes the following operations, in the order in which they should be performed:

- Reviewing software options and installing software (installation notes that supplement the *Read this first* sheet).
- Preparing for and doing physical installation of the board.
- Configuring the installed software and board.
- Identifying I/O connector pins, connecting the board to interface accessories, and wiring the I/O to external circuits.

NOTE *Install the DriverLINX software before installing the KPCI-3160 board. Otherwise, the device drivers will be more difficult to install.*

Installing the software

Software options

The KPCI-3160 has two software options. The user can select a fully integrated data acquisition software package (e.g., TestPoint or LabVIEW). The user can also run a custom program in Visual C/C++, Visual Basic, or Delphi using DriverLINX (included with the hardware). A summary of the pros and cons of using integrated packages or writing custom programs is provided in the Keithley Full Line Catalog. The KPCI-3160 has fully functional driver support for use under Windows 95/98/NT.

NOTE *DriverLINX must be installed to run any applications for the board, whether they are custom-programmed applications or integrated software packages, such as TestPoint or LabVIEW.*

DriverLINX driver software for Windows 95/98/NT

DriverLINX software, supplied by Keithley with the KPCI-3160 board, provides convenient interfaces to configure and set I/O bits without register-level programming.

Most importantly, however, DriverLINX supports those programmers who wish to create custom applications using Visual C/C++, Visual Basic, or Delphi. DriverLINX accomplishes foreground and background tasks to perform data acquisition. The software includes memory and data buffer management, event triggering, extensive error checking, and context sensitive online help.

More specifically, DriverLINX provides application developers a standardized interface to over 100 services for creating foreground and background tasks for the following:

- Analog input and output
- Digital input and output
- Time and frequency measurement
- Event counting
- Pulse output
- Period measurement

In addition to basic I/O support, DriverLINX also provides:

- Built-in capabilities to handle memory and data buffer management.
- A selection of starting and stopping trigger events, including pre-triggering, mid-point triggering, and post-triggering protocols.
- Extensive error checking.
- Context-sensitive on-line help system.

Refer to your DriverLINX documentation to determine which services are supported by your KPCI-3160 board.

DriverLINX is essentially hardware independent, because its portable APIs work across various operating systems. This capability eliminates unnecessary programming when changing operating system platforms.

TestPoint

TestPoint is a fully featured, integrated application package that incorporates many commonly used math, analysis, report generation, and graphics functions. TestPoint's graphical drag-and-drop interface can be used to create data acquisition applications, without programming, for IEEE-488 instruments, data acquisition boards, and RS232-485 instruments and devices.

TestPoint includes features for controlling external devices, responding to events, processing data, creating report files, and exchanging information with other Windows programs. It provides libraries for controlling most popular GPIB instruments. OCX and ActiveX controls plug directly into TestPoint, allowing additional features from third party suppliers.

LabVIEW

LabVIEW is a fully featured graphical programming language used to create virtual instrumentation. It consists of an interactive user interface, complete with knobs, slides, switches, graphs, strip charts, and other instrument panel controls. Its data driven environment uses function blocks that are virtually wired together and pass data to each other. The function blocks, which are selected from palette menus, range from arithmetic functions to advanced acquisition, control, and analysis routines. Also included are debugging tools, help windows, execution highlighting, single stepping, probes, and breakpoints to trace and monitor the data flow execution. LabVIEW can be used to create professional applications with minimal programming.

Virtual instruments (VIs) compatible with LabVIEW are available for the KPCI-3160.

Installing DriverLINX

Refer to the *Read this first* document that accompanies your board for installation instructions.

NOTE *Always install DriverLINX before installing the board or LabVIEW support. Both TestPoint and LabVIEW support require DriverLINX to access the board's hardware resources.*

Installing application software and drivers

Installing the TestPoint support

It is anticipated that, in the future, TestPoint will implicitly support the KPCI-3160 board without installing additional drivers. Check with the following concerning current availability of TestPoint support for the KPCI-3160:

- The TestPoint technical support page of the Keithley web site (www.keithley.com).
- The TestPoint manufacturer, Capital Equipment Corporation (CEC).

Installing the LabVIEW software and driver

If you plan to use only run-time LabVIEW applications with your KPCI-3160 board, you need not install a special driver. LabVIEW run-time support is automatically installed when you install and configure DriverLINX.

However, if you plan to develop custom applications using the LabVIEW Integrated Development Environment, you must install the DriverLINX Virtual Instruments (VIs). These VIs are provided on your DriverLINX CD-ROM but do not install automatically when you install DriverLINX and your board. You must first install the LabVIEW application program and DriverLINX, then install the DriverLINX VIs.

If you do not install the VIs during the same session in which you install DriverLINX (refer to your *Read this first* document), you may install them later as follows:

1. Start `setup.exe` on the DriverLINX CD-ROM. The DriverLINX Browser introduction screen appears.
2. Click **Next** on the DriverLINX Browser introduction screen (or wait a few seconds). The DriverLINX CD Navigator screen appears.
3. On the DriverLINX CD Navigator screen, click **Install DriverLINX**. An Install These DriverLINX Components screen appears.
4. On the Install These DriverLINX Components screen, click **LabVIEW™ Support**.
5. Follow the series of on-screen instructions that appear.

Installing the KPCI-3160 board

This subsection helps you to do the following:

- Prepare for the board installation.
- Physically install the board.

CAUTION Ensure that the computer is turned OFF before installing or removing a board. Installing or removing a board while power is ON can damage your computer, the board, or both.

Handle the board in a static-controlled workstation; wear a grounded wrist strap. Discharge static voltage differences between the wrapped board and the handling environment before removing the board from its protective wrapper. Failure to discharge static electricity before and during handling may damage semiconductor circuits on the board.

Handle the board using the mounting bracket. Do not touch the circuit traces or connector contacts when handling the board.

Checking resources for the board

Ensure that your computer has sufficient resources, particularly power resources, to run your KPCI-3160 board. Check the capacity of the computer power supply and the power requirements of your computer and presently installed boards. Then check the additional power requirements for this board. (Refer to [Appendix A](#), “[Specifications](#).”) If necessary, free resources by uninstalling other boards.

System responsibility

The system integrator has final responsibility for the EMC of a system containing Keithley KPCI-3160 boards. The user must not assume that installation of the CE-marked KPCI-3160 in a CE-marked PC will result in a system with acceptable RFI emissions.

Unwrapping and inspecting the board

NOTE *Install the DriverLINX software before installing the KPCI-3160 board. Otherwise, the device drivers will be more difficult to install.*

After you remove the wrapped board from its outer shipping carton, unwrap and inspect it as follows:

1. Your board is packaged at the factory in an anti-static wrapper. Do not remove the anti-static wrapper until you have discharged any static electricity voltage differences between the wrapped board and the environment. Wear a grounded wrist strap. A grounded wrist strap discharges static electricity from the wrapped board as soon as you hold it. Keep the wrist strap on until you have finished installing the board.
2. Remove the KPCI-3160 board from its anti-static wrapping material. (Store the wrapping material for future use.)
3. Inspect the board for damage. If damage is apparent, arrange to return the board to the factory. Refer to [Section 5](#), “[Troubleshooting](#).”
4. Check the remaining contents of your package against the packing list and immediately report any missing items.
5. If the inspection is satisfactory, proceed to “[Installing the board](#).”

Installing the board

Install a KPCI-3160 board in a PCI expansion slot on your computer as follows:

1. Turn power OFF to the computer and to any external circuits attached to the board.
2. Remove the computer chassis cover.
3. Select an unoccupied PCI expansion slot in the rear panel, and remove the corresponding dummy mounting plate.
4. Insert the PCI connector of the board into the selected PCI slot of the computer. Take care not to interfere with neighboring boards. Ensure that the board is properly seated in the slot.
5. Secure the mounting bracket of the board to the chassis, using the retaining screw that you removed when you removed the dummy mounting plate.
6. Continue with the next subsection, “[Configuring and checking the board and DriverLINX installations](#).”

Configuring and checking the board and DriverLINX installations

This subsection helps you to do the following:

- Configure the combined board and DriverLINX installations, using the DriverLINX Plug and Play Wizard.
- Check the combined board and DriverLINX installations by checking the ability to start the DriverLINX PIO Control Panel.

Configuring the combined board and DriverLINX installations

After physically installing the board, turn on and reboot the computer. The DriverLINX Plug and Play Wizard screen appears automatically. Run the Wizard immediately by following the progressive instructions on the screen.

If you do not run the Wizard immediately (you cancel the Wizard after rebooting) it will normally appear automatically on subsequent reboots until you complete the final page of the Wizard. However, it is also possible to manually restart it later during the same computer session, as follows:

1. Open the Windows Explorer.
2. Double click on X:\DrvLINX4\Help\kpci3160.bat, where X = the letter of the drive on which you installed DriverLINX. The Wizard appears.

NOTE *You can also start this batch file directly from the CD-ROM by double clicking on Y:\DrvLINX4\Help\kpci1800.bat, where Y = the drive letter of your CD-ROM drive.*

3. On the Plug and Play Wizard, click Wizard and follow the series of on-screen instructions that appear. The wizard will first lead you through the steps of installing your hardware—from a software viewpoint—and configuring it.
4. After you have finished configuring the board and DriverLINX, continue with the next subsection “[Checking the combined board and DriverLINX installations.](#)”

Checking the combined board and DriverLINX installations

Before making any connections to the board, check the combined board and DriverLINX installations. The ability to start the AIO Panel utility, which is available after you install DriverLINX, verifies that DriverLINX and the board are installed and configured satisfactorily and are working together.

1. Try starting the AIO Panel as follows:
 - a. Click the Windows 95/98/NT Start tab.
 - b. In the Start menu, click Programs.
 - c. Under DriverLINX ▾ Test Panels, find the AIO Panel entry.
 - d. Click on the AIO Panel entry. The Analog I/O Panel should appear.
 - e. Based on the results of step 1d, do one of the following:
 - If you are able to start the AIO Panel, skip to the next subsection, “[Connecting the KPCI-3160 board.](#)”
 - If you are not able to start the AIO Panel, then continue with step 2.

2. If you are unable to start the AIO Panel utility, then check to ensure that the installation is properly configured and DriverLINX is properly installed. Refer to the subsection “Configuring the KPCI-3160” in the DriverLINX manual *Using DriverLINX with your Hardware—Keithley KPCI-3160*. To access this manual on-line, do the following:
 - a. Click the Windows 95/98/NT Start tab.
 - b. In the Start menu, click Programs.
 - c. Find the DriverLINX folder, under which you should find the On-line Manuals entry.
 - d. Click on the On-line Manuals entry. The DriverLINX Printable Documentation table of contents opens via Acrobat reader.
 - e. Scroll through the DriverLINX Printable Documentation table of contents and find Configuration.
 - f. Under Configuration, click Hardware References. A list of documents appears.
 - g. In the list of documents, click on Using DriverLINX with Your Hardware—Keithley KPCI-3160. The manual opens via Acrobat Reader.
 - h. Print the manual now, if possible, to make reference easier.

NOTE *Acrobat Reader must already be installed. If necessary, you can first install Acrobat Reader directly from the CD-ROM by double clicking X:\Acrobat\setup.exe.*

If your data acquisition system has no printer, you can display and print the manual from the CD-ROM at another system. From Windows Explorer, select the CD-ROM drive (drive “X”). To display the Using DriverLINX with Your Hardware—Keithley PIO Series manual, double click on X:\Drvlinx4\Docs\Notes\kpci3160.pdf.

3. Reconfigure the installation as required, and if necessary, also reinstall DriverLINX.

NOTE *If you reinstall DriverLINX, refer also to your Read this first sheet (which is also available on the CD-ROM that came with your board). Make sure that DriverLINX installs smoothly and completely.*

4. Try again to start the AIO Panel (refer to step 1).
5. Based on the results of step 4, do one of the following:
 - If you can now start the AIO Panel, DriverLINX and the board are installed and configured properly and are working together. Proceed to the next subsection, “[Connecting the KPCI-3160 board](#).”
 - If you are still unable to start the AIO Panel, refer to [Section 5, “Troubleshooting,”](#) for additional procedures that may help you isolate the problem.

Connecting the KPCI-3160 board

This subsection helps you to do the following:

- Identify pin assignments on the board.
- Connect interface accessories.
- Wire the KPCI-3160 I/O to your external circuits.

Identifying I/O connector pin assignments on the KPCI-3160 I/O connector

The board has a 100-pin mini-D type I/O connector. Figure 3-1 and Table 3-1 define and describe the pin assignments for the KPCI-3160 I/O connector (P101). Figure 3-2 shows the location of the KPCI-3160 I/O connector.

Figure 3-1
Pin assignments for the KPCI-3160 I/O connector (P101)

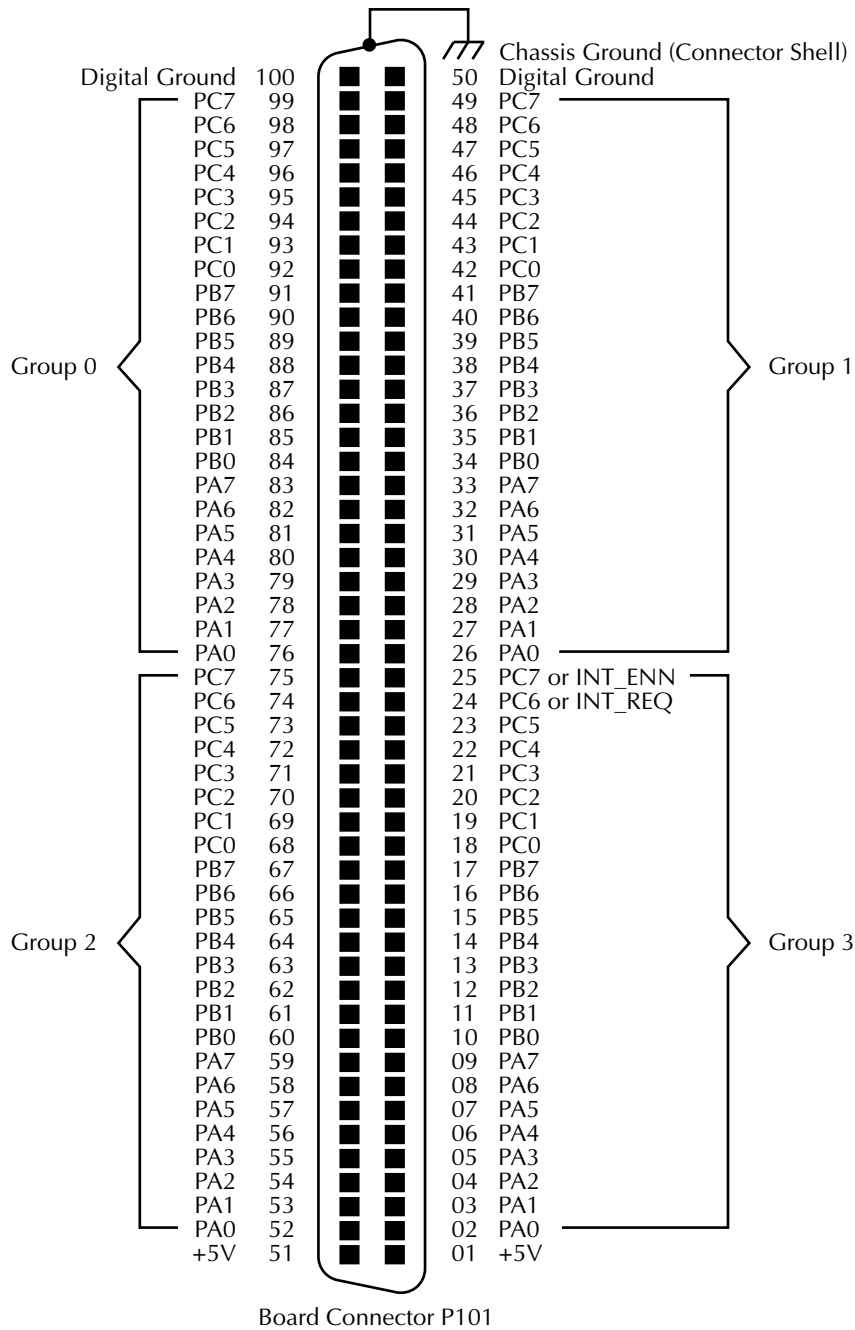
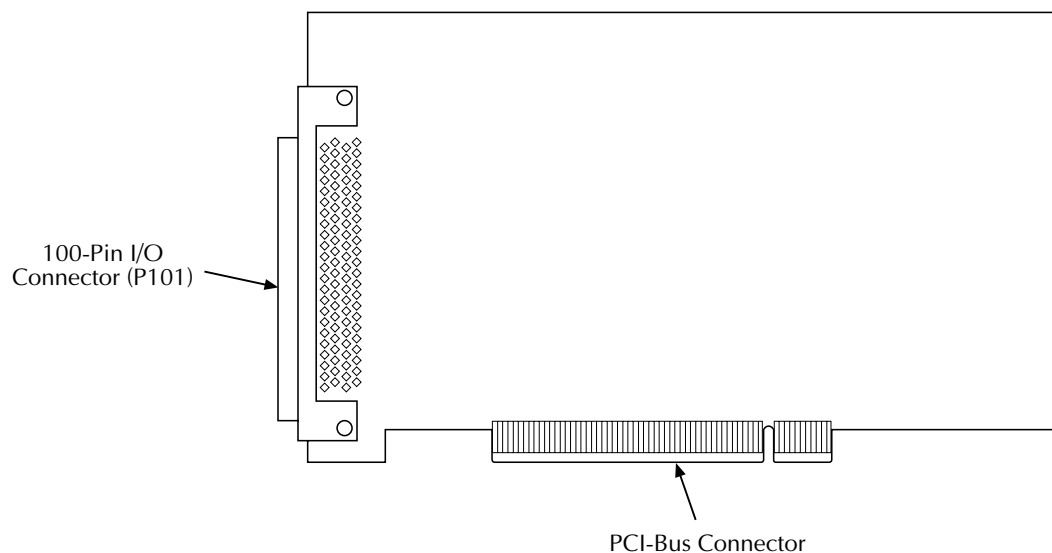

Table 3-1

Pin descriptions for KPCI-3160 I/O connector (P101)

Pin Number	Signal	Description
For port group 0, pins 76 to 83 For port group 1, pins 26 to 33 For port group 2, pins 52 to 59 For port group 3, pins 02 to 09	PA0 to PA7	The eight I/O bits of port A (an identical port A being available for each of the four port groups). PA0 is the least significant bit (LSB) of port A and PA7 is the most significant bit (MSB). You can configure port A of each port group independently, through DriverLINX, such that its eight bits are all inputs or all outputs.
For port group 0, pins 84 to 91 For port group 1, pins 34 to 41 For port group 2, pins 60 to 67 For port group 3, pins 10 to 17	PB0 to PB7	The eight I/O bits of port B (an identical port B being available for each of the four port groups). PB0 is the least significant bit (LSB) of port B and PB7 is the most significant bit (MSB). You can configure port B of each port group independently, through DriverLINX, such that its eight bits are all inputs or all outputs.
For port group 0, pins 92 to 99 For port group 1, pins 42 to 49 For port group 2, pins 68 to 75 For port group 3, pins 18 to 25	PC0 to PC7 (Port group 3 pins 24 and 25 can be alternatively configured as INT_ENN and INT_REQ)	The eight I/O bits of port C (an identical port C being available for each of the four port groups). PC0 is the least significant bit (LSB) of port C and PC7 is the most significant bit (MSB). Through DriverLINX you can do the following for each port group: Configure the upper four bits of port C independently such that they are all inputs or all outputs. Configure the lower four bits of port C independently, through DriverLINX, such that they are all inputs or all outputs.
01 and 51	+5V	+5V power from the PCI bus.
50 and 100	Signal ground	Digital common from the PCI bus.
Shell	Chassis ground	Provides a shield-ground connection when shielded cable (Keithley part number CAB-1800/S) is used to interface the board to external circuits.

Figure 3-2

Connector locations on the KPIC-3160 board

Connecting interface accessories

CAUTION If a cable is connected to any external circuits, make sure power to all external circuits is turned OFF before connecting this cable to the KPCI-3160 board. Connecting a powered external circuit to the board can damage the board, the external circuit, or both.

Handle the board at the mounting bracket, using a grounded wrist strap. Do not touch the circuit traces or connector contacts. If you do not have a grounded wrist strap, periodically discharge static electricity by placing one hand firmly on a grounded metal portion of the computer chassis.

The KPCI-3160 I/O connector can be mated directly to your external circuits using locally fabricated cable assemblies. To mate a locally fabricated cable to an I/O connector, install a 3M type 101A0-6000EC connector on the cable.

NOTE The 100-pin mating connector is NOT available in a solder-cup version; use of the specified connector will require appropriate cable and tooling to make a reliable insulation displacement connection.

Alternatively, the connectors can be mated to your circuits via manufactured cable assemblies and interface accessories, such as an adapter accessory and screw terminal boards. Use of such accessories is described in the next subsections.

Using a CONN-3160-D1 accessory

The CONN-3160-D1 is an adapter accessory for the KPCI-3160 board, as shown in [Figure 3-3](#). It provides four 50-pin connectors that are identical to the four 50-pin connectors of the KPCI-PIO96 and PIO-96J boards. These four connectors allow all accessories that work with both KPCI-PIO96 and PIO-96J boards to be used with the KPCI-3160 board. (Refer to the next subsection.) The correspondence between the pins of the CONN-3160-D1 50-pin connectors and the pins of the KPCI-3160 I/O connector is shown in [Table 3-2](#), [Table 3-3](#), [Table 3-4](#), and [Table 3-5](#).

The CONN-3160-D1 accessory interfaces to the KPCI-3160 via a CAB-1800 cable. The CAB-1800 cable is a 100-conductor cable with a 100-pin D-type connector on each end.

Figure 3-3
The CONN-3160-D1 accessory

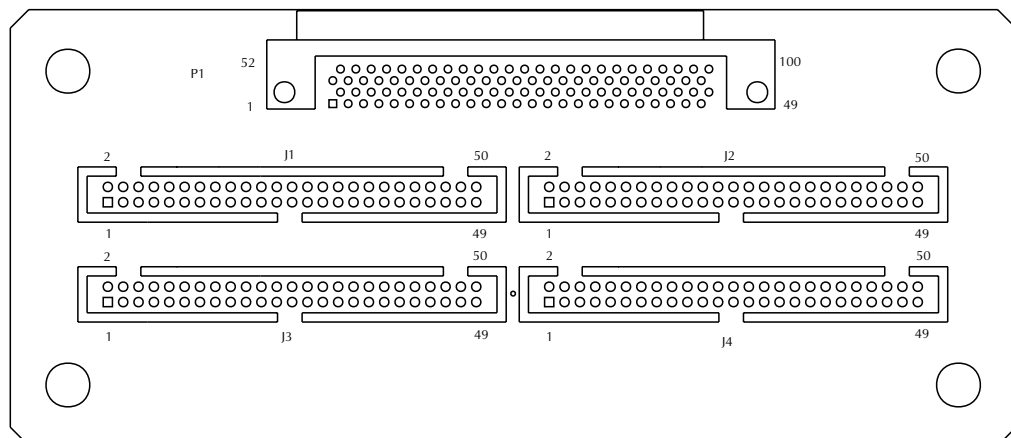

Using an STP-100U accessory

The STP-100U is an adapter accessory for the KPCI-3160 which simply brings all 100 pins of the connector to screw terminals. Pin assignments are the same as for the CONN-3160-D1 P1 connector. This differs from the KPCI-3160's P101 connector, see cabling caution below.

NOTE *While the STP-100 has a similar appearance, it uses a different pin numbering scheme compatible with the DAS/KPCI-180xHC series, and connects certain signal lines together. Because of this, it cannot be used as an accessory with the KPCI-3160 board.*

Cabling caution for accessories

Note that the CAB-1800 series is not a 1-1 cable. Because of its construction, pin assignments on one end are mirrored from that on the other end. This is why the pin numberings (and therefore screw terminal assignments) on the accessories are not the same as those of the KPCI-3160 P101 connector. Use the provided tables ([Table 3-2](#) through [Table 3-5](#)) to identify the correct connection.

Table 3-2

Port-group 0 pin-to-pin correspondence between CONN-3160-D1 50-pin and 100-pin connectors, STP-100U 100-pin connector, and the KPCI-3160 I/O connector

Port-Group 0 Signal	Pin of CONN-3160-D1 Port-Group 0 50-pin Connector (J1)	Pin of either the CONN-3160-D1 or STP-100U 100-pin Interface Connector (P1)	Pin of KPCI-3160 100-pin I/O Connector (P101)
PA0	15	75	76
PA1	13	74	77
PA2	11	73	78
PA3	09	72	79
PA4	07	71	80
PA5	05	70	81
PA6	03	69	82
PA7	01	68	83
PB0	47	67	84
PB1	45	66	85
PB2	43	65	86
PB3	41	64	87
PB4	39	63	88
PB5	37	62	89
PB6	35	61	90
PB7	33	60	91
PC0	31	59	92
PC1	29	58	93
PC2	27	57	94
PC3	25	56	95
PC4	23	55	96
PC5	21	54	97
PC6	19	53	98
PC7	17	52	99
Digital ground	All even-numbered pins	01	100
+5V	49	50	51

Table 3-3

Port-group 1 pin-to-pin correspondence between CONN-3160-D1 50-pin and 100-pin connectors, STP-100U 100-pin connector, and the KPCI-3160 I/O connector

Port-Group 1 Signal	Pin of CONN-3160-D1 Port-Group 1 50-pin Connector (J3)	Pin of either the CONN-3160-D1 or STP-100U 100-pin Interface Connector (P1)	Pin of KPCI-3160 100-pin I/O Connector (P101)
PA0	15	25	26
PA1	13	24	27
PA2	11	23	28
PA3	09	22	29
PA4	07	21	30
PA5	05	20	31
PA6	03	19	32
PA7	01	18	33
PB0	47	17	34
PB1	45	16	35
PB2	43	15	36
PB3	41	14	37
PB4	39	13	38
PB5	37	12	39
PB6	35	11	40
PB7	33	10	41
PC0	31	09	42
PC1	29	08	43
PC2	27	07	44
PC3	25	06	45
PC4	23	05	46
PC5	21	04	47
PC6	19	03	48
PC7	17	02	49
Digital ground	All even-numbered pins	51	50
+5V	49	100	01

Table 3-4

Port-group 2 pin-to-pin correspondence between CONN-3160-D1 50-pin and 100-pin connectors, STP-100U 100-pin connector, and the KPCI-3160 I/O connector

Port-Group 2 Signal	Pin of CONN-3160-D1 Port-Group 2 50-pin Connector (J2)	Pin of either the CONN-3160-D1 or STP-100U 100-pin Interface Connector (P1)	Pin of KPCI-3160 100-pin I/O Connector (P101)
PA0	15	99	52
PA1	13	98	53
PA2	11	97	54
PA3	09	96	55
PA4	07	95	56
PA5	05	94	57
PA6	03	93	58
PA7	01	92	59
PB0	47	91	60
PB1	45	90	61
PB2	43	89	62
PB3	41	88	63
PB4	39	87	64
PB5	37	86	65
PB6	35	85	66
PB7	33	84	67
PC0	31	83	68
PC1	29	82	69
PC2	27	81	70
PC3	25	80	71
PC4	23	79	72
PC5	21	78	73
PC6	19	77	74
PC7	17	76	75
Digital ground	All even-numbered pins	01	100
+5V	49	50	51

Table 3-5
Port-group 3 pin-to-pin correspondence between CONN-3160-D1 50-pin and 100-pin connectors, STP-100U 100-pin connector, and the KPCI-3160 I/O connector

Port-Group 3 Signal	Pin of CONN-3160-D1 Port-Group 3 50-pin Connector (J4)	Pin of either the CONN-3160-D1 or STP-100U 100-pin Interface Connector (P1)	Pin of KPCI-3160 100-pin I/O Connector (P101)
PA0	15	49	02
PA1	13	48	03
PA2	11	47	04
PA3	09	46	05
PA4	07	45	06
PA5	05	44	07
PA6	03	43	08
PA7	01	42	09
PB0	47	41	10
PB1	45	40	11
PB2	43	39	12
PB3	41	38	13
PB4	39	37	14
PB5	37	36	15
PB6	35	35	16
PB7	33	34	17
PC0	31	33	18
PC1	29	32	19
PC2	27	31	20
PC3	25	30	21
PC4	23	29	22
PC5	21	28	23
PC6 or INT_REQ	19	27	24
PC7 or INT_ENN	17	26	25
Digital ground	All even-numbered pins	51	50
+5V	49	100	01

Using additional accessories

Connecting additional accessories to your KPCI-3160 board through a CONN-3160-D1 accessory is illustrated in [Figure 3-4](#). Each item in [Figure 3-4](#) is described briefly in [Table 3-6](#). For more information about these products, refer to your data-acquisition or full-line Keithley catalog or consult with your Keithley dealer.

Figure 3-4
Using additional accessories with the KPCI-3160

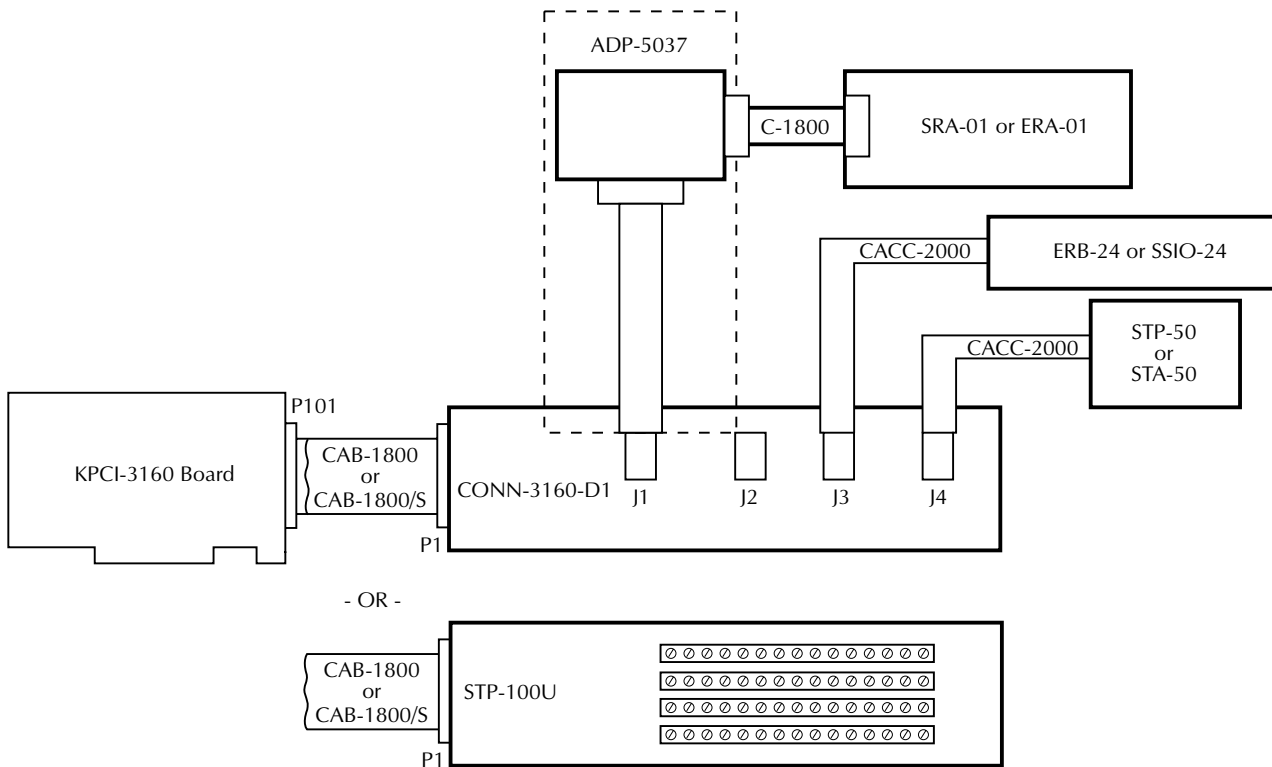

Table 3-6
Description of manufactured cables and accessories

Cable/Accessory	Description
ADP-5037	50-pin to 37-pin conversion cable.
CAB-1800	100-conductor cable with a 100-pin D-type connector on each end.
CAB-1800/S	Shielded version of CAB-1800.
CACC-2000	Cable, 24-inch, 50 conductor. Interfaces CONN-3160-D1 to STA-50, STP-50, ERB-24 or SSIO-24.
CONN-3160-D1	Adapter accessory for the KPCI-3160 board providing 50-pin headers.
ERA-01	8-channel SPDT relay output assembly. Requires C1800 and ADP-5037 cables.
ERB-24	24-channel DPDT relay output board. Requires CACC-2000 cable.
SRA-01	8-channel solid-state I/O module accessory. Requires C1800 and ADP-5037 cables.
SSIO-24	24-channel solid-state I/O module board. Requires CACC-2000 cable.
STA-50	Universal 50-pin screw terminal board. Requires CACC-2000 cable.
STP-50	Screw terminal panel with 50-pin male header. Requires CACC-2000 cable.
STP-100U	Adapter accessory for the KPCI-3160 board providing universal 100-pin screw terminals.

The standard CACC-2000 cable is 24 inches (two feet) long. You can order a longer cable as part number CACC-20NN. The suffix NN is the additional number of feet needed beyond the standard two foot length.

Wiring I/O to your external circuits

CAUTION Ensure that both the computer and the external circuits are turned OFF before making any connections. Making connections while the computer and external circuits are powered can damage the computer, the board, and the external circuits.

External circuits must properly match the input and output requirements of the board. For example, input signals often require pull-up resistors and elimination of contact bounce. The following subsection presents pull-up and de-bounce circuits and discusses using +5VDC power from the board for these and other applications.

Monitoring contact closure at an input

To ensure that the KPCI-3160 reliably monitors an open contact as an input-high condition, connect a 10k Ω pull-up resistor between the input line and a +5VDC source. See Figure 3-5.

Figure 3-5
Contact-closure monitoring at a KPCI-3160 board input

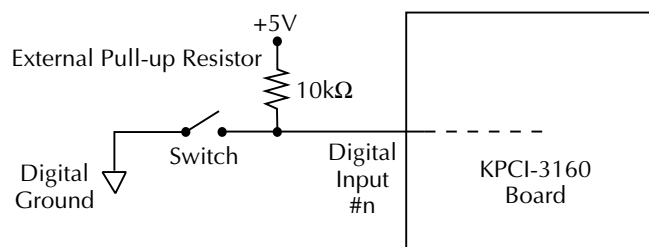

Eliminating contact bounce at an input

The effects of contact bounce may be eliminated by programming in your application software. However, it is often desirable to eliminate contact bounce from the signal, using a de-bounce circuit between the contacts and the KPCI-3160 input. Figure 3-6 shows a typical de-bounce circuit that can be used with Form C contacts.

Figure 3-6
De-bounce circuit for an input of a KPCI-3160 board

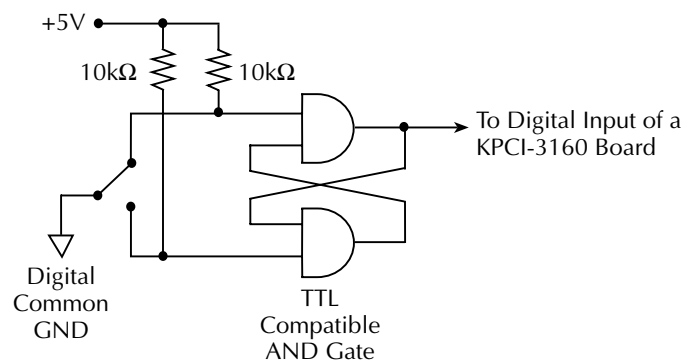

Using +5VDC from the computer power supply

CAUTION Do not connect the +5VDC outputs to an external +5VDC supply. This may damage the external supply, the board, and the computer.

Do not draw more than 2.0A, total, from the board to power external circuits, distributed as follows:

- Do not draw more than 1A, total, at the KPCI-3160 I/O connector between pin 51 (+5VDC) and pin 100 (digital ground).

OR

at CONN-3160-D1 50-pin connectors J1 and J2 combined, between pins 49 (+5VDC) and the even-numbered pins (digital grounds).

- Do not draw more than 1A, total, at the KPCI-3160 I/O connector between pin 01 (+5VDC) and pin 50 (digital ground).

OR

at CONN-3160-D1 50-pin connectors J3 and J4 combined, between pins 49 (+5VDC) and the even-numbered pins (digital grounds).

Drawing excessive current may damage the KPCI-3160 board and, potentially, the computer.

The board extends fuse-protected power from the +5VDC computer supply to the I/O connector. (See [Figure 3-1](#)). This power is convenient for use in light external circuits, such as pull-up resistors. If you ensure that the conditions in the above **CAUTION** notice are maintained, this power may also be used to energize external accessories, provided that your computer's power supply is capable of delivering the desired current.

4

External Interrupts

Using DriverLINX, you can arrange for a piece of software code to run every time that the board detects the rising edge and/or the falling edge of an external interrupt signal. Section 4 explains external interrupt signal connections and summarizes interrupt usage for the KPCI-3160 board. For more information, refer to *Using DriverLINX with Your Hardware—Keithley 3160* and other DriverLINX manuals.

External interrupt description

Through DriverLINX, you can alternatively configure two of the general-purpose I/O lines of port group 3—PC7 and PC6—for the following external interrupt functions:

- $\overline{\text{INT_ENN}}$ (external interrupt enable, active low)
- INT_REQ (external interrupt request, edge triggered)

The interrupt pins on the I/O connector of the KPCI-3160 board, and the corresponding pins on the J4 connector of the CONN-3160-D1 accessory, are identified in Table 4-1.

Table 4-1

Connector pins used for external interrupt function

Interrupt Function		Group 3 connector pin that is configurable for either interrupt or general-purpose functions		Corresponding General-Purpose Function
Description	Signal Designator	On the KPCI-3160 I/O Connector, P101	On CONN-3160-D1 Connector J4	
External interrupt enable	$\overline{\text{INT_ENN}}$	25	17	PC7
External interrupt request	INT_REQ	24	19	PC6

Through DriverLINX, you can independently configure any of the four port groups so that an external interrupt request pulse latches the data sent to the input ports.

Through DriverLINX, you can also configure interrupts to be edge-triggered for any of the following conditions:

- The rising (positive) edge of the external interrupt request signal
- The falling (negative) edge of the external interrupt request signal
- Both the rising and falling edges of the external interrupt request signal

NOTE *Positive-edge triggering is the default upon power-up or reset.*

In principle, if you configure interrupts to occur on both the rising and falling edges of the external interrupt request signal, each signal generates two interrupt requests—the on-period width of the external interrupt request signal determining the time between these two requests. However, in practice, be aware that the falling edge of the external interrupt signal is effective *only if the interrupt signal is on longer than the combined overhead and data processing time initiated by the rising edge of the signal*. If the falling edge of the signal occurs during data processing initiated by the rising edge of the signal, then the falling edge of the signal will not be effective—it will be missed. Refer to the next subsection, “External interrupt application,” for more information about missed interrupts.

External interrupt application

Typically, you would use an external interrupt to ensure that the application program processes, at a specific time (or at two specific times, if both positive-edge and negative-edge triggering are used), specific data that are present at one or more ports. You can do this with a KPCI-3160 external interrupt, subject to the following limitations:

- A KPCI-3160 external interrupt signal indiscriminately triggers data transfer from all twelve I/O ports: both data that *does* need to be processed and data that *does not* need to be processed. The board provides no way to assign interrupts or intrinsically detect the interrupt status for a specific port. (However, you could potentially hardware-set and software-detect certain I/O bits to tell a custom application program which ports to process for a given interrupt. Or you could compare the current and previous data sets, and then process only changed data.)
- Conversely, if processing needs and interrupts occur too frequently, data that *does* need to be processed can be *missed*. External interrupt signals are ignored during an interrupt service routine (ISR) while an interrupt-pending bit is set high—except that the first interrupt miss, only, does set an interrupt-missed bit.

Therefore, you must 1) know how fast your host computer and application software can process data, and 2) space important data and interrupts accordingly. Of course, this requirement is not specific to the KPCI-3160 board. It applies to any data acquisition board.

You must also ensure, at the end of interrupt-initiated processing, that the application program resets the interrupt-pending bit, the interrupt-missed bit, and two other bits that recorded whether the interrupt occurred on the rising or falling edge of the interrupt request signal. DriverLINX handles this automatically.

Refer to [Table 4-2](#) for a list of external-interrupt responses.

For an additional application illustration, refer to the “[Interrupt example scenario](#)” subsection in [Appendix B](#). For information on setting and configuration of external interrupts, refer to your DriverLINX software manuals.

NOTE *Do not confuse the external interrupt `INT_REQ` with the internal PCI bus interrupt `INTA`, even though `INT_REQ` and `INTA` are linked by software. (The PCI bus shares one interrupt line, `INTA`, for all boards. `INTA` interrupts the host computer each time a transfer is occurring.)*

Table 4-2
External-interrupt responses

Result	Interrupt Control/Status Register Interrupt Control Bits (x = don't care)		Port Group Control Register (x = don't care)		External Inputs at P101		Interrupt Control/ Status Register Status after Edge Transition*
	INT Enable Bit 12	Polarity Bit 6	Bit 6	Bit 5	Enable Pin 25	Edge Pin 24	Polarity Bit 17
PCI-INT; No Latch	1	0	x	0	0	↑	1
PCI-INT; No Latch	1	1	x	0	0	↓	1
No PCI-INT; No Latch (Programmed I/O Mode)	0	x	x	0	0	↑ or ↓	0
No PCI-INT; Latch Input Data	0	x	0	1	0	↑	1
No PCI-INT; No Latch	0	x	0	1	0	↓	0
No PCI-INT; No Latch	0	x	1	1	0	↑	0
No PCI-INT; Latch Input Data	0	x	1	1	0	↓	1
No PCI-INT; No Latch (Programmed I/O Mode)	x	x	x	x	1	↑ or ↓	0
PCI-INT; Latch Input Data	1	0	0	1	0	↑	1
No PCI-INT; Latch Input Data	1	1	0	1	0	↑	1
No PCI-INT; No Latch	1	0	0	1	0	↓	0
PCI-INT; No Latch	1	1	0	1	0	↓	1
PCI-INT; No Latch	1	0	1	1	0	↑	1
No PCI-INT; No Latch	1	1	1	1	0	↑	0
No PCI-INT; Latch Input Data	1	0	1	1	0	↓	1
PCI-INT; Latch Input Data	1	1	1	1	0	↓	1

*For bit 17, assume an initial clear state before edge.

5

Troubleshooting

If your KPCI-3160 board is not operating properly, use the information in this section to isolate the problem before calling Keithley Applications Engineering. If you then need to contact an applications engineer, refer to [“Technical support.”](#)

Identifying symptoms and possible causes

First try to isolate the problem using [Table 5-1](#), which lists general symptoms and possible solutions for KPCI-3160 board problems.

Table 5-1

Basic troubleshooting information

Symptom	Possible Cause	Possible Cause Validation/Solution
Computer does not boot when board is installed.	Resource conflict. KPCI-3160 series board is conflicting with other boards in the system.	1. Validate the cause of the conflict. Temporarily unplug boards—especially ISA boards ¹ —one at a time, and try booting the computer. Repeat until a boot is attained. 2. Try resolving conflicts by reinstalling one PCI board at a time and rebooting after each reinstallation. ² However, you may ultimately need to change ISA board resource allocations, such as base address or interrupt assignments.
	Board not seated properly.	Check the installation of the board.
	The power supply of the host computer is too small to handle all the system resources.	Check the needs of all system resources and obtain a larger power supply.
Board does not respond to the AIO Panel.	DriverLINX is not installed properly or is not configured properly.	Refer to “Checking the combined board and DriverLINX installations.” Check the Windows® Device Manager and follow the installation troubleshooting instructions in the DriverLINX on-line help.
	The board is incorrectly aligned in the expansion slot.	Check the board for proper seating.
	The board is damaged.	Contact Keithley Applications Engineering.
Data appears to be invalid.	An open connection exists.	Check screw terminal wiring.
	Transducer is not connected to channel being read.	Check the transducer connections.
	One or more external circuits are not TTL compatible.	Check external circuit schematics. Test external circuits with a logic probe.
+5V power is not available at I/O connector.	External circuit digital output and power loads exceed current capacity of the board, tripping self-resetting fuses.	Check external circuits for shorts. Check the external circuit load (must be less than 2.0A, total, and less than 1.0A, each, at pins 01 and 51 of the I/O connector).
Intermittent operation.	Vibrations or loose connections exist.	Cushion source of vibration and tighten connections.
	The board is overheating.	Check environmental and ambient temperature. See your computer documentation.
	Electrical noise exists.	Check for AC power lines in close proximity to signal lines. Provide better shielding or reroute unshielded wiring.
System lockup during operation.	A timing error occurred.	Restart your computer. Then analyze your program by debugging and narrowing the list of possible failure locations.

¹Plug and Play cannot tell if an ISA board already uses an address it assigns to a PCI board.

²Plug and Play may then assign different, nonconflicting addresses to the PCI boards.

If your board is not operating properly after using the information in [Table 5-1](#), continue with “[Systematic problem isolation](#)” to further isolate the problem.

Systematic problem isolation

General problem isolation procedure

If you were unable to isolate the problem using [Table 5-1](#), then follow [Figure 5-1](#) and the accompanying written procedure. The flowchart in [Figure 5-1](#) summarizes how to systematically check and eliminate some problem causes. The corresponding written procedure amplifies the flowchart steps with more detail.

CAUTION Always turn OFF your computer and any external circuits connected to the KPCI-3160 board before removing or replacing the board. Removing or replacing a board with the power ON can damage the board, the computer, the external circuit, or all three.

Handle the board at the mounting bracket, using a grounded wrist strap. Do not touch the circuit traces or connector contacts. If you do not have a grounded wrist strap, periodically discharge static electricity by placing one hand firmly on a grounded metal portion of the computer chassis.

NOTE In the following procedure, the term “board” always refers to a KPCI-3160 board. The procedure never directs you to install or remove any type of PCI board other than a KPCI-3160 board.

In [Figure 5-1](#), the number in brackets in each flowchart block (e.g. [21]) refers to the corresponding step number in the verbal procedure. If multiple blocks in the flowchart have the same number, each of those blocks is part of a single verbal step. Conversely, if there is a range of numbers in the brackets (e.g. [4, 5, 6]), the block summarizes multiple verbal steps.

The logic in this procedure assumes that the problem has only one cause. Therefore, once a cause is found and corrected, the reader is instructed to reassemble the system and verify proper operation.

Figure 5-1
Problem isolation flowchart

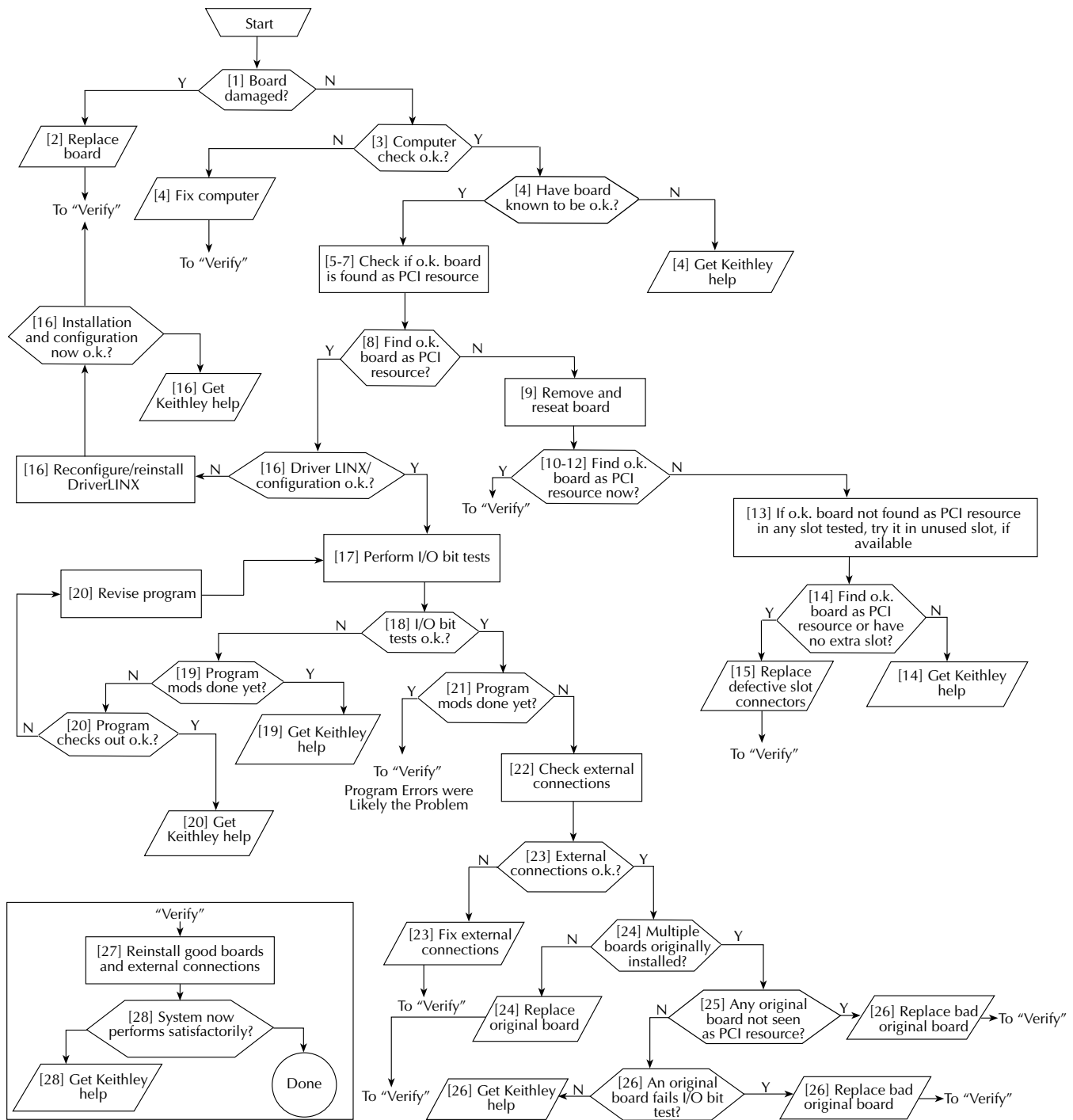

To further isolate the problem to the KPCI-3160 board or to the host computer, use the following steps:

1. Check if board damage is seen on inspection. Proceed as follows:

NOTE *If more than one KPCI-3160 board is installed in your computer, disconnect, remove, and check all KPCI-3160 boards.*

- a. Turn power OFF to the host computer.
- b. Turn power OFF to all external circuits and accessories connected to all installed KPCI-3160 boards.
- c. From each installed KPCI-3160 board, unplug the CONN-3160-D1 accessory (or in-house-wired 100-pin mating connector) that is wired to external circuits.

NOTE *Do not disconnect any circuits from the CONN-3160-D1 and associated accessories (or from the in-house-wired 100-pin mating connector, if you used that instead).*

- d. Remove all KPCI-3160 boards from the computer.
 - e. Visually inspect all KPCI-3160 boards for damage.
2. Based on the results of step 1, do the following:
 - If all KPCI-3160 boards are not obviously damaged, continue with step 3 and check for host computer malfunction.
 - If a board(s) is obviously damaged on inspection, repair or replace the board. Refer to “[Technical support](#)” for information on returning the board for repair or replacement. Skip to step 27.
 3. Check if the computer functions satisfactorily by itself. Proceed as follows:
 - a. Remove all KPCI-3160 boards from the host computer.
 - b. Turn ON power to the host computer.
 - c. Perform any necessary diagnostics to the computer hardware and operating system.
 4. Based on the results of step 3, do one of the following:
 - If the computer functions satisfactorily, the problem must lie elsewhere; do the following steps:
 - a. If you have another KPCI-3160 board that you know is OK, i.e. works properly, then continue with step 5.
 - b. If you do not have another KPCI-3160 board that you know is OK, i.e. works properly, read the instructions in “[Technical support](#).” Then contact Keithley for help in isolating the cause of your problem.
 - If the computer does not function satisfactorily, do the following steps:
 - a. Diagnose and fix the computer malfunction.
 - b. Assume that fixing the computer malfunction has solved your problem, and skip to step 27.
 5. Prepare for PCI resource checks in step 6 by clearing any KPCI-3160 board listings from the Windows 95/98 device manager. If any KPCI-3160 boards are listed, the computer could falsely report as PCI resources one or more of the now-empty PCI slots that previously held the KPCI-3160 boards.

Proceed as follows for the Windows 95/98 operating system. (A different procedure is required for Windows NT.):

- a. Right-click the **My Computer** icon on your desktop.
- b. On the menu that appears, click **Properties**.

- c. On the System Properties dialog box that appears, click the **Device Manager** tab. The Device Manager appears.
 - d. In the Device Manager look for a **DriverLINX drivers** item.
 - If you find a **DriverLINX drivers** item with a + sign to the left of the item, click the + sign. A second level list may appear containing one or more KPCI-3108 boards.
 - If you do not find a **DriverLINX drivers** item, skip to step 6.
 - e. Delete any KPCI-3160 boards, *only*, from the list, by highlighting the item and clicking the **Remove** button.
6. Check if the computer finds an OK board to be a PCI resource in a slot from which you removed a KPCI-3160 board.
 - a. Shut down Windows 95/98/NT and turn OFF power to the host computer.
 - b. Perform the procedure “[Checking for board as a PCI resource](#)” found later in [Section 5](#).
 7. If you had originally installed additional KPCI-3160 boards in other PCI slots, then repeat step 6 with the OK board in each of these other slots.
 8. Based on the results of steps 6 and 7, do one of the following:
 - a. If the board is recognized as a PCI component in all slots tested, then there may be software issues. Skip to step 16.
 - b. If the OK board is not recognized as a PCI component in all slots tested, then a PCI slot connector(s) is suspect. Continue with step 9.
 9. Make sure that the suspect slot connector and the board contacts have been wiped adequately and are properly mated. Do the following:
 - a. Turn OFF power to the host computer.
 - b. Remove and reseat the board a few times in the suspect PCI slot connector. This creates a wiping action to improve the probability of good contact.
 - c. Make sure that the board is firmly seated in the suspect PCI slot connector.
 - d. Replace the cover of the computer.
 - e. Turn ON power to the host computer.
 10. Check if the computer now finds the OK board to be a PCI resource in the suspect slot connector. Use step 3, *only*, of the procedure “[Checking for board as a PCI resource](#).”
 11. If you found more than one suspect slot connector, then repeat steps 9 and 10 with the OK board in the other suspect slot connectors.
 12. Based on the results of steps 9 through 11, do one of the following:
 - If the board was recognized as a PCI resource in all slots tested, then the cause of the problem was probably high contact resistance, which apparently has been corrected by the wiping action. Skip to step 27.
 - If the OK board was not identified as a PCI resource in all slots tested, then any slots in which it was not identified are still suspect. Continue with step 13.
 13. Based on the history of steps 6 through 12, do one of the following actions,
 - If, at this point, *both* of the following are true, then install and test the OK board in a previously unused slot to confirm that the originally tested slot(s) (rather than some other factor) was at fault:
 - The OK board was not identified as a PCI resource in *any* slot that you tested.
 - You have a PCI slot that was unused before you started the problem isolation scheme.

Proceed as follows:

- a. Turn OFF power to the host computer.
- b. Move the OK KPCI-3160 board to the slot that was unused before you started the problem isolation scheme.
- c. Reinstall the cover of the computer.

- d. Perform step 3, only, of the procedure “Checking for board as a PCI resource,” found later in [Section 5](#).
 - e. Continue with step 14.
 - If, at this point, you do not have a PCI slot that was unused before you started the problem isolation scheme, continue with step 14.
 14. Based on the history of steps 6 through 13, do one of the following:
 - If, at any point in steps 6 through 13, the OK board was identified as a PCI resource in at least one slot on the host computer, then any slot in which it did not work is likely defective. Continue with step 15.
 - If you only had one slot in which to install the OK board, assume that this slot is defective. Continue with step 15.
 - However, if at this point you have tested the OK board in multiple slots and the board has not been identified as a PCI resource in *any* slot, then the cause of your problem may be outside the scope of these diagnostics. Read the instructions in “[Technical support](#),” and then contact Keithley for help in isolating the cause of your problem.
 15. Replace the defective slot connector, as follows:
 - a. Turn OFF the computer.
 - b. Remove the OK board.
 - c. Have a qualified service person replace the defective PCI slot connector.
 - d. Skip to step 27.
 16. Continuing from step 8, check whether DriverLINX is installed and configured properly to work with the board and, if problems are found, try to remedy them.
 - a. Check whether you can start the AIO Panel. Refer to steps 1a through 1d of “[Checking the combined board and DriverLINX installations](#)” in [Section 3](#).
 - b. Based on the results of step 16a above, do one of the following:
 - If the AIO Panel starts, the board and DriverLINX are installed and configured properly. Skip to step 17 of the problem isolation scheme. Your problem may be caused by faulty I/O.
 - If the AIO Panel does not start, the combined board and DriverLINX are not configured properly, or DriverLINX is not installed properly. Continue with step 16c of the problem isolation scheme.
 - c. Perform steps 2 through 4 of “[Checking the combined board and DriverLINX installations](#)” in [Section 3](#).
 - d. Based on the results of step 16c above, do one of the following:
 - If the AIO Panel now starts, then skip to step 27.
 - If the AIO Panel still does not start, then your problem may be outside the scope of these diagnostics. Read the instructions in “[Technical support](#),” and then contact Keithley for help in isolating the cause of your problem.
 17. Perform the following I/O bit tests to determine whether you can write and read all I/O bits to and from the OK board: the I/O loop-back test and the output set test. Perform either or both of these tests, outlined separately under the headings “[I/O loop-back test](#)” and “[Output set test](#).” *However, only the I/O loop-back is conclusive and is therefore strongly preferred.*
 18. Based on the results of step 17, do one of the following:
 - If you can write and read all I/O bits to and from the OK board, skip to step 21.
 - If you cannot write and read all I/O bits to and from the OK board, there may be data acquisition program errors or defective slot contacts corresponding to I/O bits; continue with step 19.

19. You have arrived at this step because you cannot write and read all I/O bits to and from the OK board. You may have already tried some data acquisition program source-code debugging. Do one of the following:
 - If *either* of the following statements are true, then continue with step 20.
 - You have arrived at step 19 before debugging the source code.
 - You have arrived at step 19 after debugging the source code once, but you have not yet tried to find more code bugs after two or more I/O test failures.
 - If *both* of the following statements are true, then the cause of your problem may be outside the scope of these diagnostics. Read the instructions in “[Technical support](#),” and then contact Keithley for help in isolating the cause of your problem:
 - You have arrived again at step 19 after having debugged the source code at least once and after having failed the I/O bit tests at least a second time.
 - You have tried to find more code bugs after two or more I/O test failures and cannot find any more bugs.
20. Thoroughly check if all data acquisition program source-code lines are OK. Check the program documentation and/or use a debugger to look for programming errors that may be causing the problem.
 - If programming errors are found, do the following:
 - a. Debug and fix all known data acquisition program errors.
 - b. Repeat steps 17 and 18.
 - If no programming errors are found after thorough debugging, then the cause of your problem may be outside the scope of these diagnostics. Read the instructions in “[Technical support](#),” and then contact Keithley for help in isolating the cause of your problem.
21. If you can write and read all I/O bits to and from the OK board, do the following:
 - If you have arrived at step 21 after program corrections have been made, and you can now write and read all I/O bits to and from the OK board, then the problem has apparently been resolved. Skip to step 27.
 - If you have arrived at step 21 without making data acquisition program corrections and can write and read all I/O bits to and from the OK board, then faulty external I/O connections may have caused your problem. Continue with step 22.
22. Check for external wiring faults as follows:
 - a. Into the OK KPCI-3160 board, plug back one of the CONN-3160-D1 accessories (or a in-house-wired 100-pin mating connector) that is wired to external circuits. You unplugged one or more of these in step 1.
 - b. Check each external I/O connection, one at a time, for short circuits and open circuits and immediately correct any faults as you find them.
 - c. If KPCI-3160 boards were installed in more than one PCI slot, repeat steps 22a and 22b until all external circuits have been checked and all faults have been corrected.
23. Based on the results of step 22, do the following:
 - If any external I/O connection faults were found and corrected, assume that your problems were caused by the faulty connections. Skip to step 27.
 - If all external I/O connections were found to be normal, then, by process of elimination, the KPCI-3160 board(s) originally installed in the computer is likely the cause of the problem. Continue with step 24.

24. Replace the faulty board(s). Do one of the following:
 - If only one KPCI-3160 board was installed when the problem occurred, proceed as follows:
 - a. Leave the OK board in the expansion slot as a replacement. To repair or replace the faulty board, contact Keithley as described in “[Technical support](#).”
 - b. Skip to step 27.
 - If more than one board was installed when the problem occurred, determine which one is faulty, starting with step 25.
25. Check whether an original board—a board that you removed in step 1—is detected as a PCI resource. Proceed as follows for the Windows 95/98 operating system (a different procedure is required for Windows NT):
 - a. Turn OFF the computer.
 - b. Remove the OK KPCI-3160 board.
 - c. Reinstall the computer cover.
 - d. Turn ON the computer.
 - e. Clear KPCI-3160 boards from Windows 95/98 device manager, if any are listed. (Otherwise, when you reboot the computer, the computer may still say that empty PCI slots that once held the OK KPCI-3160 board are PCI resources.) Proceed as follows:
 1. Right-click the **My Computer** icon on your desktop.
 2. On the menu that appears, click **Properties**.
 3. On the System Properties dialog box that appears, click the **Device Manager** tab. The Device Manager appears.
 4. In the Device Manager, look for a **DriverLINX drivers** item.
 5. If you find a **DriverLINX drivers** item with a + sign to the left of the item, click the + sign. A second level list may appear containing one or more KPCI-3108 boards.
 6. Delete any KPCI-3160 boards, *only*, from the list, by highlighting the item and clicking the **Remove** button.
 - f. Perform step 1, only, of the procedure “[Checking for board as a PCI resource](#),” found later in this section.
 - g. Turn OFF the computer.
 - h. Install one of the original KPCI-3160 boards in a PCI slot known to be satisfactory.
 - i. Reinstall the computer cover.
 - j. Perform step 3, only, of the procedure “[Checking for board as a PCI resource](#),” found later in this section.
 - k. Based on the results of step 25j, do one of the following:
 - If, in step 25j, the original board that you checked is not recognized as a PCI resource, you have located the faulty board. Do the following:
 1. Replace it with the OK board. (To repair the faulty board or obtain a new one, contact Keithley as described in “[Technical support](#).”)
 2. Skip to step 27.
 - If, in step 25j, the original board that you checked is recognized as a PCI resource, but you have not yet checked all original KPCI-3160 boards as PCI resources, repeat steps 25e through 25k for each additional original board.
 - If you have reached this point after checking all original KPCI-3160 boards as PCI resources, and each board has been recognized as a PCI resource, then continue with step 26. Probably one of the boards has faulty I/O.

26. Determine which original board has faulty I/O. If the faulty board survived the PCI resource test in step 25, it should fail the I/O test.
 - a. If an original board remains installed following step 25, then skip to step 26e.
 - b. Turn OFF the computer.
 - c. Install one of the original boards in a slot known to be satisfactory.
 - d. Turn ON the computer.
 - e. Perform the test outlined in the “[I/O loop-back test](#)” subsection. Then return to this step (26e).
 - f. Based on the results of step 26e, do one of the following:
 - If, in step 26e, you *cannot* write and read all I/O bits to and from the first original KPCI-3160 board that you test, you have located the faulty board; replace it with the OK board. (To repair the faulty board or obtain a new one, contact Keithley as described in “[Technical support](#).”) Then skip to step 27.
 - If, in step 26e, you *can* write and read all I/O bits to and from the first original KPCI-3160 board that you test, repeat steps 26b through 26e for additional original KPCI-3160 boards until you find a faulty board. Replace the faulty board with the OK board. (To repair the faulty board or obtain a new one, contact Keithley as described in “[Technical support](#).”) Then continue with step 27.
 - However, if you have reached this point after trying all original boards, and the I/O on each board has been found satisfactory, then the cause of your problem may be outside the scope of these diagnostics. Read the instructions in “[Technical support](#),” and then contact Keithley for help in isolating the cause of your problem.
27. Assuming the problem has been resolved, do the following:
 - a. Turn OFF the computer.
 - b. Install the good KPCI-3160 boards in good slots.
 - c. Reinstall the computer cover.
 - d. Reconnect all external circuits as discussed in [Section 3](#), “[Installation](#).”
 - e. Turn ON the computer.
 - f. Verify that the system now performs satisfactorily.
28. Based on the results of step 27f, select one of the following:
 - If the system now performs satisfactorily, you have successfully isolated and corrected the problem.
 - If the system still does not perform satisfactorily, then the cause of your problem may be outside the scope of these diagnostics. Read the instructions in “[Technical support](#),” and then contact Keithley for help in isolating the cause of your problem.

Specified tests

Checking for board as a PCI resource

CAUTION The test outlined in this subsection involves handling of the KPCI-3160 circuit board. Handle the board at the mounting bracket, using a grounded wrist strap. Do not touch the circuit traces or connector contacts. If you do not have a grounded wrist strap, periodically discharge static electricity by placing one hand firmly on a grounded metal portion of the computer chassis.

Ensure that the computer is turned OFF before installing or removing a board. Installing or removing a board while power is ON can damage your computer, the board, or both.

Always reinstall the cover before turning the computer ON.

NOTE The following procedure depends on the Plug and Play capability of Windows 95 or 98. If your computer operating system is Windows NT, you must use a different procedure to detect the board as a PCI resource. Consult your Windows NT documentation.

The following procedure provides details to help you determine whether Windows 95/98 Plug and Play finds your KPCI-3160 board as a PCI resource.

1. Determine the PCI resources that Plug and Play detects before any KPCI-3160 boards are installed. Proceed as follows:
 - a. Insert a blank diskette, or any diskette that you are sure is unbootable, into the A: drive.
 - b. Turn ON the computer and allow it to start the boot cycle.

The boot cycle stalls at a text screen listing system characteristics and resources and saying at the bottom: **Non-system disk or disk error. Replace and press any key when ready.**

NOTE This system characteristics and resources screen is normally displayed only fleetingly during the boot cycle. Having an unbootable diskette in your computer automatically stops the boot cycle at this screen, allowing for convenient viewing. This is not harmful to your computer. The more common approach—using the PAUSE key to pause the boot cycle at this screen—requires fast reflexes with some systems.

- c. Note the displayed list of PCI devices under a heading something like **PCI device listing...** If you have a printer, print the screen by pressing the PRINT SCREEN key.
 - d. Remove the diskette and allow the boot cycle to finish.
 2. Install a good board—a KPCI-3160 board that you know is fully functional—as follows:
 - a. Shut down Windows 95/98 and turn OFF power to the host computer.
 - b. Install the good board in a slot from which you removed a potentially faulty board. Refer to “Installing the KPCI-3160 board” near the beginning of [Section 3](#), for board installation instructions.
 - c. Reinstall the cover of the computer.

NOTE *If you removed more than one board in step 1, install only one good board in one expansion slot.*

Do not connect any external circuits to the board at this point.

3. Again determine the PCI resources detected by your computer, after the KPCI-3160 board is installed. Windows 95/98 Plug and Play should find and configure the new board as a PCI resource if all of the following are true:
 - The board functions properly as a PCI device.
 - The contacts of the expansion slot in which the OK board is installed are in good condition.
 - The OK board is seated properly in the expansion slot.

Do the following, as you did in step 1:

- a. Insert an unbootable diskette.
- b. Turn ON the computer and allow the boot cycle to stall at the **Non-system disk or disk error...** message.
- c. Again, note the displayed list of PCI devices. A new device should be listed, likely as an unidentified peripheral. If your resource listing includes PCI slot numbers, the slot number for the new device should match the number of the slot in which your board is installed.
- d. Remove the diskette and allow the boot cycle to finish.

I/O bit tests

CAUTION The tests outlined in this subsection involve handling of the KPCI-3160 circuit board. Handle the board at the mounting bracket, using a grounded wrist strap. Do not touch the circuit traces or connector contacts. If you do not have a grounded wrist strap, periodically discharge static electricity by placing one hand firmly on a grounded metal portion of the computer chassis.

Ensure that the computer is turned OFF before installing or removing a board. Installing or removing a board while power is ON can damage your computer, the board, or both.

Always reinstall the cover before turning the computer ON.

The I/O bit tests check whether the input and output functions of the board are operating properly. They also act as backup tests for a defective slot connector. Of the two tests outlined below, *only the I/O loop-back test is conclusive and is therefore strongly preferred.*

These tests are intended to be used when requested in the “[General problem isolation procedure](#).” However, they may also be used for general performance checks.

I/O loop-back test

The I/O loop-back test checks input and output bit performance.

You prepare a specially wired loop-back connector that, for each of the four port groups that you test, connects the bits of port A to the corresponding bits of ports B and C. (Alternatively, you wire the screw terminals of an STP-50 or STA-50 accessory and connect a CACC-2000 cable.) The loop-back connections are summarized in [Table 5-2](#).

Table 5-2

Loop-back connection summary

Connect these bits configured as an output	PA0 ↓	PA1 ↓	PA2 ↓	PA3 ↓	PA4 ↓	PA5 ↓	PA6 ↓	PA7 ↓
to these bits configured as inputs	PB0 PC0	PB1 PC1	PB2 PC2	PB3 PC3	PB4 PC4	PB5 PC5	PB6 PC6	PB7 PC7

After connecting a CONN-3160-D1 accessory to your KPCI-3160 board, you insert the loopback connector into connector J1 of the CONN-3160-D1 accessory. Then, you use a DriverLINX graphical interface (AIO Panel) to configure the bits of port group 0, port A as outputs and the bits of port group 0, ports B and C, as inputs. Thereafter, you use this same DriverLINX graphical interface to set two different bit patterns at port A and to check in each case for corresponding bit patterns at ports B and C.

If all bits correspond for the first port group, you repeat the loop-back test for each of the other three port groups. The board is performing satisfactorily if all 96 bits respond appropriately.

Perform the loop-back test as follows:

1. Prepare a loop-back test connector, using a female 50-pin connector that mates with any of the 50-pin connectors on the CONN-3160-D1 accessory. This can be purchased as 3M part no. 3425-6050. Wire the connector as shown in Figure 5-2.

Alternatively, wire an STP-50 or STA-50 screw terminal accessory as shown in Figure 5-2. The screw terminal numbers and assignments for the STP-50 or STA-50 accessory are the same as the pin numbers and assignments for the 3M 3425-6050 connector. After connecting a CACC-2000 cable, you can use the wired STP-50 or STA-50 in the same way as a loop-back connector. (See Figure 3-4.)

Figure 5-2
Mating connector wiring for loop-back test

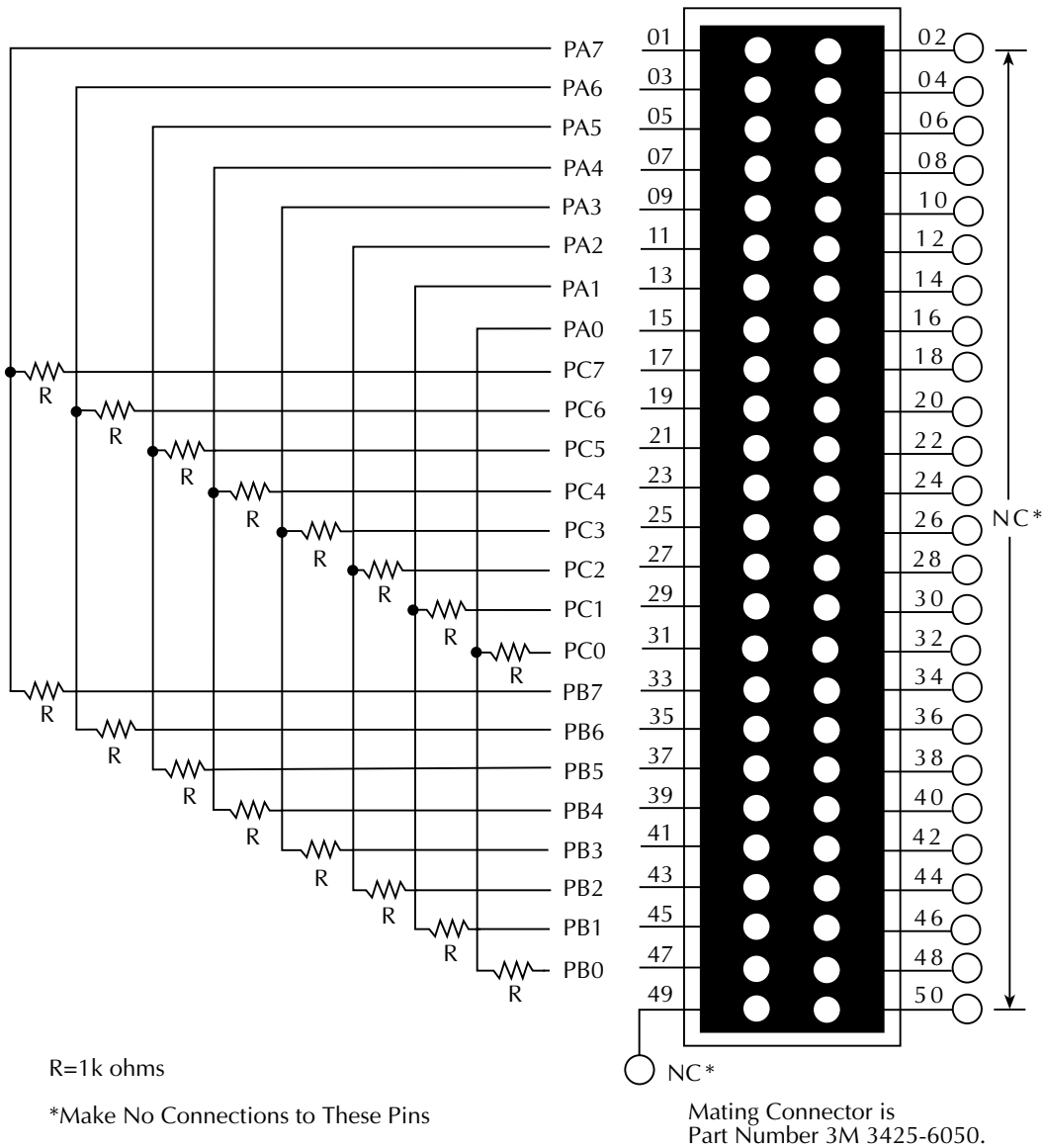

NOTE *Resistors in the loops are specified for safety. During the loop-back procedure, some of the interconnected bits could temporarily or inadvertently be configured both as outputs, and the board could be easily damaged. These 1K ohm resistors limit the currents between bits to below 15mA, which is within the source and sink current specifications for the board. If you wish to use a different resistance value, the substitute resistance value must be at least 700 ohms.*

2. Turn OFF the host computer.
3. Connect a CONN-3160-D1 accessory to your KPCI-3160 board. Refer to “Using a CONN-3160-D1 accessory” in Section 3.
4. Insert the loop-back test connector, which you prepared in step 1, into the CONN-3160-D1 connector designated in Table 5-3. (For connector locations, see Figure 3-3.)
Alternatively, if you wired an STP-50 or STA-50 accessory instead of the 3M 3425-6050 connector, insert the free end of the CACC-2000 connecting cable into the STA-3160D1 connector designated in Table 5-3.

Table 5-3

Where to insert the loop-back connector

If you are testing this group of A, B, and C ports:	Then plug the wired 3M 3425-6050 connector or wired STP-50/STA-50 accessory into this CONN-3160-D1 50-pin connector:
Port group 0	J1
Port group 1	J3
Port group 2	J2
Port group 3	J4

5. Turn ON the host computer and boot Windows 95/98/NT.
6. Click the Windows 95/98/NT **Start** tab.

7. Start the AIO Panel as follows:
 - a. In the **Start** menu, click **Programs**.
 - b. Find the **DriverLINX ▶ Test Panels** folder, under which you should find the **AIO Panel** entry.
 - c. Click on the **AIO Panel** entry. The **Analog I/O Panel** should appear, similar to the example in Figure 5-3. (If you have other DriverLINX devices installed in addition to the KPCI-3160, they will also be listed. In that case, select the KPCI-3160 and the proper device number before proceeding.)

Figure 5-3
An AIO Panel example

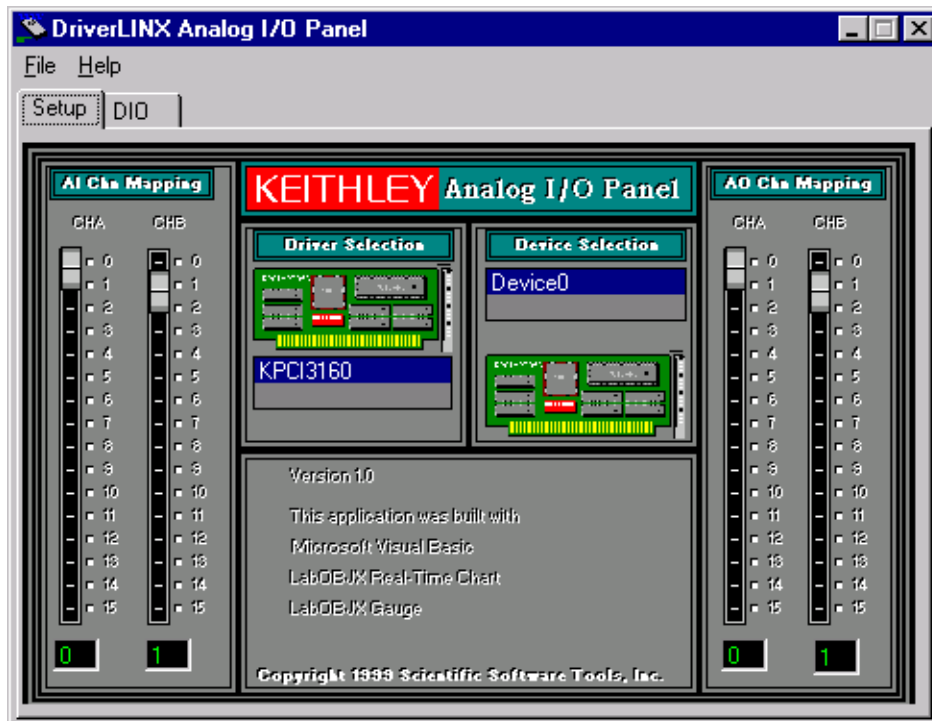

8. On the AIO Control Panel, click the **DIO** tab.

Figure 5-4
DIO channel tab example

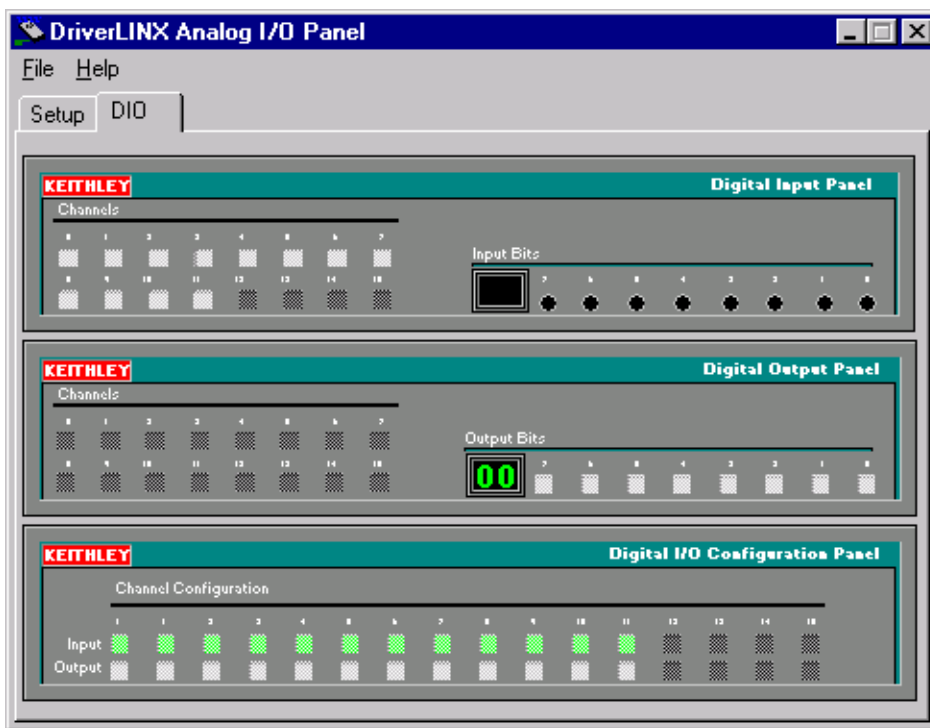

NOTE The on-screen digital I/O controller works as follows:

- Channels 0 to 11 refer to the twelve 8-bit general-purpose registers in the KPCI-3160. Bits displayed on the **Digital Input Panel** and the **Digital Output Panel** are numbered 0-7 for every channel. Refer to [Table 5-4](#).

Table 5-4
Channel information

Logical channel	DriverLINX function	KPCI-3160 external connector
0	Digital Input/Output Port	Digital input/output lines Group 0 PA0-PA7
1	Digital Input/Output Port	Digital input/output lines Group 0 PB0-PB7
2	Digital Input/Output Port	Digital input/output lines Group 0 PC0-PC7
3	Digital Input/Output Port	Digital input/output lines Group 1 PA0-PA7
4	Digital Input/Output Port	Digital input/output lines Group 1 PB0-PB7
5	Digital Input/Output Port	Digital input/output lines Group 1 PC0-PC7
6	Digital Input/Output Port	Digital input/output lines Group 2 PA0-PA7

Table 5-4 (cont.)
Channel information

Logical channel	DriverLINX function	KPCI-3160 external connector
7	Digital Input/Output Port	Digital input/output lines Group 2 PB0-PB7
8	Digital Input/Output Port	Digital input/output lines Group 2 PC0-PC7
9	Digital Input/Output Port	Digital input/output lines Group 3 PA0-PA7
10	Digital Input/Output Port	Digital input/output lines Group 3 PB0-PB7
11	Digital Input/Output Port	Digital input/output lines Group 3 PC0-PC7

- *Invalid channels and settings appear as dark gray squares. For example:*
 - *Non-existent channels always appear as dark gray squares.*
 - *Channels configured as inputs will appear as dark grey squares on the output panel.*
- *Valid channels and settings appear as white squares when OFF and green squares when ON. (When the manual is printed in black and white, valid channels and settings appear as white squares when OFF and as light gray squares when ON.)*
- *The two-digit numeric displays under **Input Bits** and **Output Bits** show the hexadecimal values of the adjacent bit patterns.*
- *To configure a valid channel either for input or output, use the **Digital Channel Configuration Panel**. Click on either the **Input** or **Output** square below the channel number.*
- *To turn ON output-channel bits, use the **Digital Output Panel**. First select the channel number of the bits to be turned on by clicking on the appropriate square under **Channels**. Then, turn ON a bit by clicking the appropriate square under **Output Bits**. Turn OFF a bit in the same way.*
- *To read an input-channel bit, use the **Digital Input Panel**. First select the channel number to be checked by clicking the appropriate square under **Channels**. Then, read the numbered bit under **Input Bits**. OFF input bits appear as black dots and ON input bits appear as green dots. (When the manual is printed in black and white, OFF input bits appear as black dots and ON input bits appear as light gray dots.)*

- Under **Digital I/O Configuration Panel**, configure channels 0 to 2 as shown in [Figure 5-5](#).

Figure 5-5
Configuring the digital I/O channels as inputs and outputs

KEITHLEY		Digital I/O Configuration Panel															
Channel Configuration																	
		0	1	2	3	4	5	6	7	8	9	10	11	12	13	14	15
Input	<input type="checkbox"/>	<input checked="" type="checkbox"/>	<input checked="" type="checkbox"/>	<input checked="" type="checkbox"/>	<input checked="" type="checkbox"/>	<input checked="" type="checkbox"/>	<input checked="" type="checkbox"/>	<input checked="" type="checkbox"/>	<input checked="" type="checkbox"/>	<input checked="" type="checkbox"/>	<input checked="" type="checkbox"/>	<input checked="" type="checkbox"/>	<input checked="" type="checkbox"/>	<input type="checkbox"/>	<input type="checkbox"/>	<input type="checkbox"/>	<input type="checkbox"/>
Output	<input checked="" type="checkbox"/>	<input type="checkbox"/>	<input type="checkbox"/>	<input type="checkbox"/>	<input type="checkbox"/>	<input type="checkbox"/>	<input type="checkbox"/>	<input type="checkbox"/>	<input type="checkbox"/>	<input type="checkbox"/>	<input type="checkbox"/>	<input type="checkbox"/>	<input type="checkbox"/>	<input checked="" type="checkbox"/>	<input checked="" type="checkbox"/>	<input checked="" type="checkbox"/>	<input checked="" type="checkbox"/>

NOTE For clarity when the manual is printed in black and white, the control colors in [Figure 5-5](#) and subsequent drawings will be shown as follows:

Illustration	Color on Actual Panel	Function
BLACK	DARK GREY	Invalid
WHITE	LIGHT GREY	OFF
GREY	GREEN	ON

- In the **Digital Output Panel** under **Channels**, click on channel 0 as shown in [Figure 5-6](#).

Figure 5-6
Configuring channel 0 for output bit pattern A

KEITHLEY		Digital Output Panel																
Channels																		
		0	1	2	3	4	5	6	7	Output Bits								
	<input checked="" type="checkbox"/>	<input type="checkbox"/>	<input type="checkbox"/>	<input type="checkbox"/>	<input type="checkbox"/>	<input type="checkbox"/>	<input type="checkbox"/>	<input type="checkbox"/>	<input type="checkbox"/>	55	<input type="checkbox"/>	<input checked="" type="checkbox"/>	<input type="checkbox"/>	<input checked="" type="checkbox"/>	<input type="checkbox"/>	<input checked="" type="checkbox"/>	<input type="checkbox"/>	<input checked="" type="checkbox"/>
	<input type="checkbox"/>	<input type="checkbox"/>	<input type="checkbox"/>	<input type="checkbox"/>	<input type="checkbox"/>	<input type="checkbox"/>	<input type="checkbox"/>	<input type="checkbox"/>	<input type="checkbox"/>		<input type="checkbox"/>	<input type="checkbox"/>	<input type="checkbox"/>	<input type="checkbox"/>	<input type="checkbox"/>	<input type="checkbox"/>	<input type="checkbox"/>	<input type="checkbox"/>

- In the **Digital Output Panel** under **Output Bits**, set the bits of channel 0 for bit pattern A as shown in [Figure 5-6](#).
- In the **Digital Input Panel** under **Channels**, click on channel 1 as shown in [Figure 5-7](#).

Figure 5-7
Proper response of channel 1 input bits when channel 0 output bits are set to bit pattern A

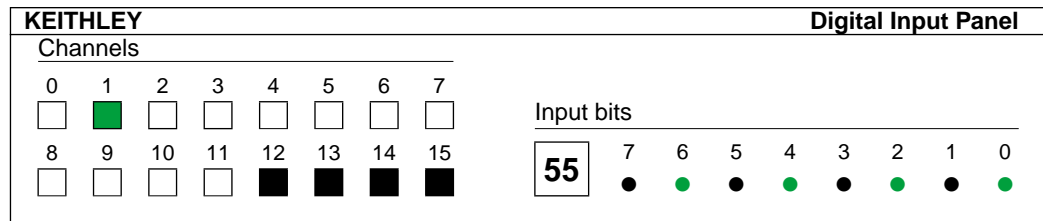

13. In the **Digital Input Panel** under **Input bits** observe the bit pattern. Figure 5-7 shows the proper response. (Here, bits which are on are shown in grey. They will be green on the actual display.)
 - If the observed input bit patterns are not the same as shown in Figure 5-7, the digital I/O is not functioning properly. Stop here, and return to the problem isolation step that asked you to perform the General-purpose digital I/O hardware test.
 - If the input bit patterns are the same as shown in Figure 5-7, continue with step 14.
14. In the **Digital Input Panel** under **Channels**, click on channel 2 as shown in Figure 5-8.

Figure 5-8
Proper response of channel 2 input bits when channel 0 output bits are set to bit pattern A

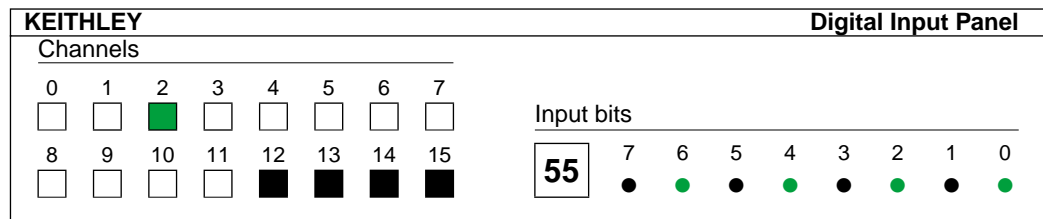

15. In the **Digital Input Panel** under **Input bits** observe the bit pattern. Figure 5-8 shows the proper response.
 - If the observed input bit patterns are not the same as shown in Figure 5-8, the digital I/O is not functioning properly. Stop here, and return to the problem isolation step that asked you to perform the General-purpose digital I/O hardware test.
 - If the input bit patterns are the same as shown in Figure 5-8, continue with step 16.
16. In the **Digital Output Panel** under **Channels**, click on channel 0 as shown as shown in Figure 5-9.

Figure 5-9
Configuring channel 0 for output bit pattern B

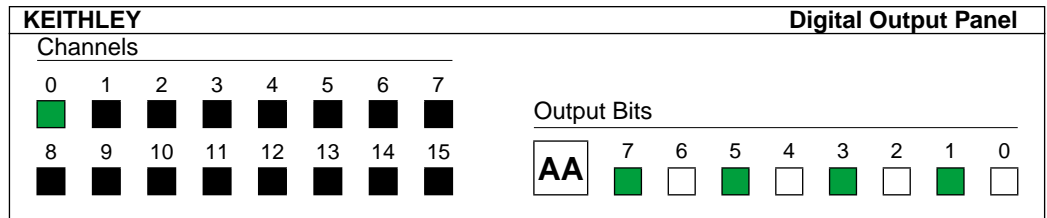

17. In the **Digital Output Panel** under **Output Bits**, set the bits of channel **0** for bit pattern B as shown in [Figure 5-9](#).
18. In the **Digital Input Panel** under **Channels**, click on channel 1 as shown in [Figure 5-10](#).

Figure 5-10
Proper response of channel 1 bits when channel 0 output bits are set to bit pattern B

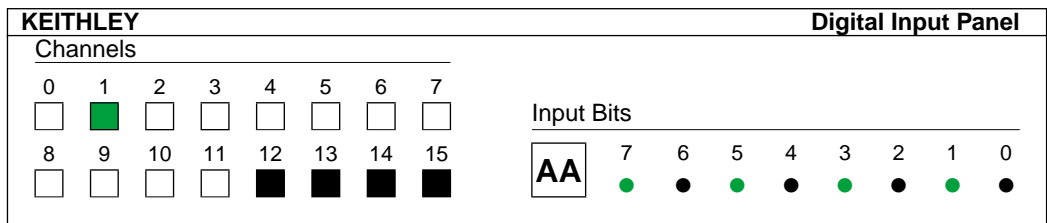

19. In the **Digital Input Panel** under **Input bits** observe the bit pattern. [Figure 5-10](#) shows the proper response.
 - If the observed input bit patterns are not the same as shown in [Figure 5-10](#), the digital I/O is not functioning properly. Stop here, and return to the problem isolation step that asked you to perform the General-purpose digital I/O hardware test.
 - If the input bit patterns are the same as shown in [Figure 5-10](#), continue with step 20.
20. In the **Digital Input Panel** under **Channels**, click on channel 2 as shown in [Figure 5-11](#).

Figure 5-11
**Proper response of channel 2 bits when channel 0 output bits
 are set to bit pattern B**

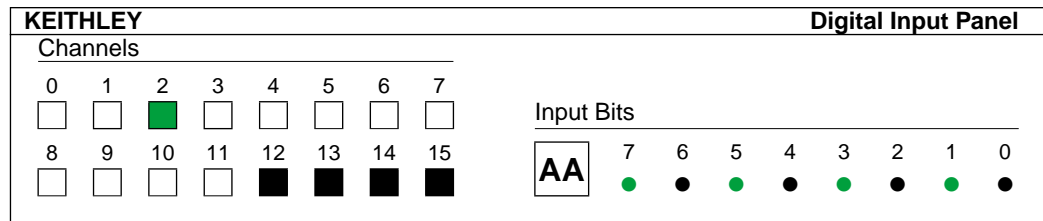

21. In the **Digital Input Panel** under **Input bits** observe the bit pattern. Figure 5-11 shows the proper response.
 - If the observed input bit patterns are not the same as shown in Figure 5-11, the digital I/O is not functioning properly. Stop here, and return to the problem isolation step that asked you to perform the General-purpose digital I/O hardware test.
 - If the input bit patterns are the same as shown in Figure 5-11, the digital I/O is functioning properly.
22. Based on the observations in step 21, do the following:
 - If the bit patterns for ports A, B, and C do all agree, but you have not performed the loop-back test for all four port groups, then repeat steps 2 through 21 for the next port group.
 - If the bit patterns for ports A, B, and C do all agree, and you have performed a loop-back test for all four port groups, the board is functioning properly. Stop here, and return to the step in the “[General problem isolation procedure](#)” where you were directed to do I/O bit tests (step 17 or 26e in the “[General problem isolation procedure](#)”). Or, optionally, now perform the output set test, as discussed in the next subsection, if you have not already done so.

Output set test

The output set test checks whether logic levels measured at all KPCI-3160 output pins agree with output bit patterns set by software, using a DriverLINX graphical interface (AIO Panel).

NOTE *This test is performed without user circuits being connected to the outputs.*

Perform the output set test as follows:

1. Ready the following equipment:
 - A digital voltmeter (DVM) or a digital multimeter (DMM) set to measure voltages, or a logic probe capable of reading TTL logic levels.
 - A CONN-3160-D1 accessory and CAB-1800 cable.
 - A means to reliably and safely connect the DMM/DVM or logic probe input to each KPCI-3160 I/O point. The following alternatives are suggested, both of which mate with the CONN-3160-D1 accessory:
 - An STA-50 screw terminal accessory with attached CACC-2000 cable (refer to “Using additional accessories” in Section 3).
 - A 50-pin mating connector (3M part no. 3425-6050) with installed ribbon cable, such that the meter or logic probe can be clipped to exposed conductors at the end of the cable.
2. Turn OFF the host computer.
3. Connect the CONN-3160-D1 accessory to your KPCI-3160 board. Refer to “Using a CONN-3160-D1 accessory.”
4. Into one of the CONN-3160-D1 50-pin connectors that is designated in Table 5-5, insert either of the following:
 - The CACC-2000 cable that is attached to the STA-50
 - The cabled 50-pin mating connector.

Table 5-5

Where to insert the output-set-test accessories

If you are testing this group of A, B, and C ports:	Then plug the 3M 3425-6050 connector or STP-50/STA-50 accessory-plus-cable into this CONN-3160-D1 50-pin connector:
Port group 0	J1
Port group 1	J3
Port group 2	J2
Port group 3	J4

5. Turn ON the host computer and boot Windows 95/98/NT.
6. Click the Windows 95/98/NT **Start** tab.

7. Start the AIO Panel as follows:
 - a. In the **Start** menu, click **Programs**.
 - b. Find the **DriverLINX ▶ Test Panels** folder, under which you should find the **AIO Panel** entry.
 - c. Click on the **AIO Panel** entry. The **Analog I/O Panel** should appear, similar to the example in Figure 5-12. (If you have other DriverLINX devices installed in addition to the KPCI-3160, they will also be listed. In that case, select the KPCI-3160 and the proper device number before proceeding.)

Figure 5-12
An AIO Panel example

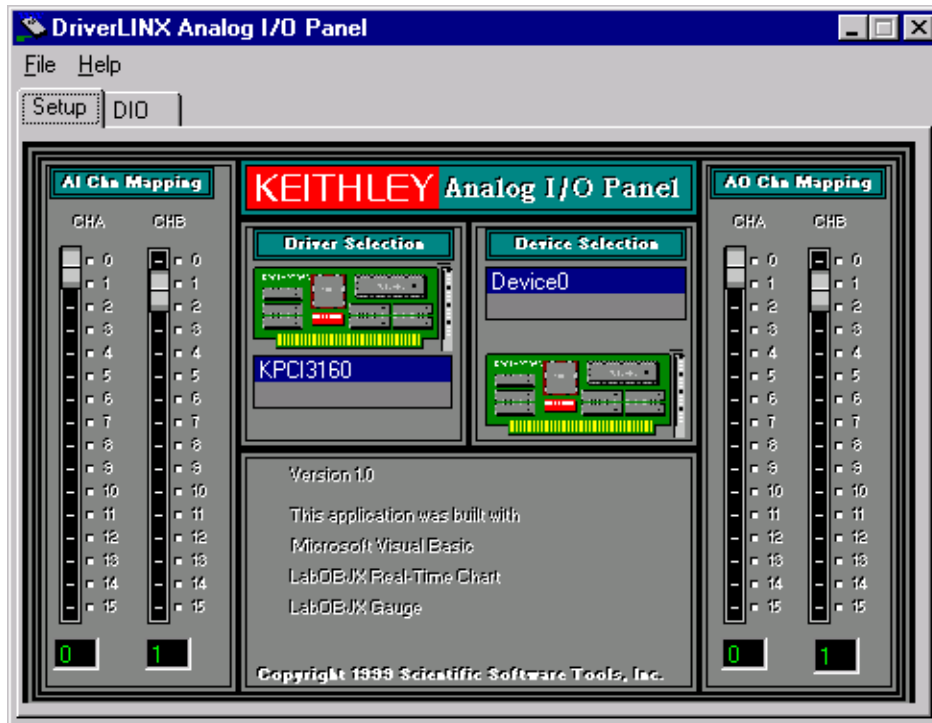

8. On the AIO Panel, click the **DIO** tab.

NOTE To read an input-channel bit, use the **Digital Input Panel**. First select the channel number to be checked by clicking the appropriate square under **Channels**. Then, read the numbered bit under **Input Bits**. OFF input bits appear as black dots and ON input bits appear as green dots. (When the manual is printed in black and white, OFF input bits appear as black dots and ON input bits appear as light gray dots.) Further information about this panel, how to make changes, and how to interpret displays, is given in “I/O Bit Tests” of this section.

- Under **Digital I/O Configuration Panel**, configure channels 0 to 2 for output as shown in [Figure 5-13](#).

Figure 5-13
Configuring the digital I/O channels as inputs and outputs

KEITHLEY		Digital I/O Configuration Panel															
Channel Configuration																	
		0	1	2	3	4	5	6	7	8	9	10	11	12	13	14	15
Input		<input type="checkbox"/>	<input type="checkbox"/>	<input type="checkbox"/>	<input checked="" type="checkbox"/>	<input checked="" type="checkbox"/>	<input checked="" type="checkbox"/>	<input checked="" type="checkbox"/>	<input checked="" type="checkbox"/>	<input checked="" type="checkbox"/>	<input checked="" type="checkbox"/>	<input checked="" type="checkbox"/>	<input checked="" type="checkbox"/>	<input checked="" type="checkbox"/>	<input checked="" type="checkbox"/>	<input checked="" type="checkbox"/>	<input checked="" type="checkbox"/>
Output		<input checked="" type="checkbox"/>	<input checked="" type="checkbox"/>	<input checked="" type="checkbox"/>	<input type="checkbox"/>	<input type="checkbox"/>	<input type="checkbox"/>	<input type="checkbox"/>	<input type="checkbox"/>	<input type="checkbox"/>	<input type="checkbox"/>	<input type="checkbox"/>	<input type="checkbox"/>	<input checked="" type="checkbox"/>	<input checked="" type="checkbox"/>	<input checked="" type="checkbox"/>	<input checked="" type="checkbox"/>

NOTE In [Figure 5-13](#) and subsequent drawings of digital I/O controller panels, the squares below invalid channels are colored black instead of dark gray—for clarity when the manual is printed in black and white.

- In the **Digital Output Panel** under **Channels**, click on channel 0 as shown in [Figure 5-14](#).

Figure 5-14
Configuring channel 0 for output bit pattern A

KEITHLEY		Digital Output Panel															
Channels																	
		0	1	2	3	4	5	6	7	Output Bits							
		<input checked="" type="checkbox"/>	<input type="checkbox"/>	<input type="checkbox"/>	<input checked="" type="checkbox"/>	<input checked="" type="checkbox"/>	<input checked="" type="checkbox"/>	<input checked="" type="checkbox"/>	<input checked="" type="checkbox"/>	<input type="checkbox"/>	<input type="checkbox"/>	<input type="checkbox"/>	<input type="checkbox"/>	<input type="checkbox"/>	<input type="checkbox"/>	<input type="checkbox"/>	<input type="checkbox"/>
		<input checked="" type="checkbox"/>	<input checked="" type="checkbox"/>	<input checked="" type="checkbox"/>	<input checked="" type="checkbox"/>	<input checked="" type="checkbox"/>	<input checked="" type="checkbox"/>	<input checked="" type="checkbox"/>	<input checked="" type="checkbox"/>	<input type="checkbox"/>	<input checked="" type="checkbox"/>	<input type="checkbox"/>	<input checked="" type="checkbox"/>	<input type="checkbox"/>	<input checked="" type="checkbox"/>	<input type="checkbox"/>	<input checked="" type="checkbox"/>
		<input checked="" type="checkbox"/>	<input checked="" type="checkbox"/>	<input checked="" type="checkbox"/>	<input checked="" type="checkbox"/>	<input checked="" type="checkbox"/>	<input checked="" type="checkbox"/>	<input checked="" type="checkbox"/>	<input checked="" type="checkbox"/>	<input type="checkbox"/>	<input type="checkbox"/>	<input type="checkbox"/>	<input type="checkbox"/>	<input type="checkbox"/>	<input type="checkbox"/>	<input type="checkbox"/>	<input type="checkbox"/>
		<input checked="" type="checkbox"/>	<input checked="" type="checkbox"/>	<input checked="" type="checkbox"/>	<input checked="" type="checkbox"/>	<input checked="" type="checkbox"/>	<input checked="" type="checkbox"/>	<input checked="" type="checkbox"/>	<input checked="" type="checkbox"/>	<input type="checkbox"/>	<input type="checkbox"/>	<input type="checkbox"/>	<input type="checkbox"/>	<input type="checkbox"/>	<input type="checkbox"/>	<input type="checkbox"/>	<input type="checkbox"/>
		<input checked="" type="checkbox"/>	<input checked="" type="checkbox"/>	<input checked="" type="checkbox"/>	<input checked="" type="checkbox"/>	<input checked="" type="checkbox"/>	<input checked="" type="checkbox"/>	<input checked="" type="checkbox"/>	<input checked="" type="checkbox"/>	<input type="checkbox"/>	<input type="checkbox"/>	<input type="checkbox"/>	<input type="checkbox"/>	<input type="checkbox"/>	<input type="checkbox"/>	<input type="checkbox"/>	<input type="checkbox"/>
		<input checked="" type="checkbox"/>	<input checked="" type="checkbox"/>	<input checked="" type="checkbox"/>	<input checked="" type="checkbox"/>	<input checked="" type="checkbox"/>	<input checked="" type="checkbox"/>	<input checked="" type="checkbox"/>	<input checked="" type="checkbox"/>	<input type="checkbox"/>	<input type="checkbox"/>	<input type="checkbox"/>	<input type="checkbox"/>	<input type="checkbox"/>	<input type="checkbox"/>	<input type="checkbox"/>	<input type="checkbox"/>
		<input checked="" type="checkbox"/>	<input checked="" type="checkbox"/>	<input checked="" type="checkbox"/>	<input checked="" type="checkbox"/>	<input checked="" type="checkbox"/>	<input checked="" type="checkbox"/>	<input checked="" type="checkbox"/>	<input checked="" type="checkbox"/>	<input type="checkbox"/>	<input type="checkbox"/>	<input type="checkbox"/>	<input type="checkbox"/>	<input type="checkbox"/>	<input type="checkbox"/>	<input type="checkbox"/>	<input type="checkbox"/>
		<input checked="" type="checkbox"/>	<input checked="" type="checkbox"/>	<input checked="" type="checkbox"/>	<input checked="" type="checkbox"/>	<input checked="" type="checkbox"/>	<input checked="" type="checkbox"/>	<input checked="" type="checkbox"/>	<input checked="" type="checkbox"/>	<input type="checkbox"/>	<input type="checkbox"/>	<input type="checkbox"/>	<input type="checkbox"/>	<input type="checkbox"/>	<input type="checkbox"/>	<input type="checkbox"/>	<input type="checkbox"/>
		<input checked="" type="checkbox"/>	<input checked="" type="checkbox"/>	<input checked="" type="checkbox"/>	<input checked="" type="checkbox"/>	<input checked="" type="checkbox"/>	<input checked="" type="checkbox"/>	<input checked="" type="checkbox"/>	<input checked="" type="checkbox"/>	<input type="checkbox"/>	<input type="checkbox"/>	<input type="checkbox"/>	<input type="checkbox"/>	<input type="checkbox"/>	<input type="checkbox"/>	<input type="checkbox"/>	<input type="checkbox"/>
		<input checked="" type="checkbox"/>	<input checked="" type="checkbox"/>	<input checked="" type="checkbox"/>	<input checked="" type="checkbox"/>	<input checked="" type="checkbox"/>	<input checked="" type="checkbox"/>	<input checked="" type="checkbox"/>	<input checked="" type="checkbox"/>	<input type="checkbox"/>	<input type="checkbox"/>	<input type="checkbox"/>	<input type="checkbox"/>	<input type="checkbox"/>	<input type="checkbox"/>	<input type="checkbox"/>	<input type="checkbox"/>
		<input checked="" type="checkbox"/>	<input checked="" type="checkbox"/>	<input checked="" type="checkbox"/>	<input checked="" type="checkbox"/>	<input checked="" type="checkbox"/>	<input checked="" type="checkbox"/>	<input checked="" type="checkbox"/>	<input checked="" type="checkbox"/>	<input type="checkbox"/>	<input type="checkbox"/>	<input type="checkbox"/>	<input type="checkbox"/>	<input type="checkbox"/>	<input type="checkbox"/>	<input type="checkbox"/>	<input type="checkbox"/>
		<input checked="" type="checkbox"/>	<input checked="" type="checkbox"/>	<input checked="" type="checkbox"/>	<input checked="" type="checkbox"/>	<input checked="" type="checkbox"/>	<input checked="" type="checkbox"/>	<input checked="" type="checkbox"/>	<input checked="" type="checkbox"/>	<input type="checkbox"/>	<input type="checkbox"/>	<input type="checkbox"/>	<input type="checkbox"/>	<input type="checkbox"/>	<input type="checkbox"/>	<input type="checkbox"/>	<input type="checkbox"/>
		<input checked="" type="checkbox"/>	<input checked="" type="checkbox"/>	<input checked="" type="checkbox"/>	<input checked="" type="checkbox"/>	<input checked="" type="checkbox"/>	<input checked="" type="checkbox"/>	<input checked="" type="checkbox"/>	<input checked="" type="checkbox"/>	<input type="checkbox"/>	<input type="checkbox"/>	<input type="checkbox"/>	<input type="checkbox"/>	<input type="checkbox"/>	<input type="checkbox"/>	<input type="checkbox"/>	<input type="checkbox"/>
		<input checked="" type="checkbox"/>	<input checked="" type="checkbox"/>	<input checked="" type="checkbox"/>	<input checked="" type="checkbox"/>	<input checked="" type="checkbox"/>	<input checked="" type="checkbox"/>	<input checked="" type="checkbox"/>	<input checked="" type="checkbox"/>	<input type="checkbox"/>	<input type="checkbox"/>	<input type="checkbox"/>	<input type="checkbox"/>	<input type="checkbox"/>	<input type="checkbox"/>	<input type="checkbox"/>	<input type="checkbox"/>
		<input checked="" type="checkbox"/>	<input checked="" type="checkbox"/>	<input checked="" type="checkbox"/>	<input checked="" type="checkbox"/>	<input checked="" type="checkbox"/>	<input checked="" type="checkbox"/>	<input checked="" type="checkbox"/>	<input checked="" type="checkbox"/>	<input type="checkbox"/>	<input type="checkbox"/>	<input type="checkbox"/>	<input type="checkbox"/>	<input type="checkbox"/>	<input type="checkbox"/>	<input type="checkbox"/>	<input type="checkbox"/>
		<input checked="" type="checkbox"/>	<input checked="" type="checkbox"/>	<input checked="" type="checkbox"/>	<input checked="" type="checkbox"/>	<input checked="" type="checkbox"/>	<input checked="" type="checkbox"/>	<input checked="" type="checkbox"/>	<input checked="" type="checkbox"/>	<input type="checkbox"/>	<input type="checkbox"/>	<input type="checkbox"/>	<input type="checkbox"/>	<input type="checkbox"/>	<input type="checkbox"/>	<input type="checkbox"/>	<input type="checkbox"/>
		<input checked="" type="checkbox"/>	<input checked="" type="checkbox"/>	<input checked="" type="checkbox"/>	<input checked="" type="checkbox"/>	<input checked="" type="checkbox"/>	<input checked="" type="checkbox"/>	<input checked="" type="checkbox"/>	<input checked="" type="checkbox"/>	<input type="checkbox"/>	<input type="checkbox"/>	<input type="checkbox"/>	<input type="checkbox"/>	<input type="checkbox"/>	<input type="checkbox"/>	<input type="checkbox"/>	<input type="checkbox"/>
		<input checked="" type="checkbox"/>	<input checked="" type="checkbox"/>	<input checked="" type="checkbox"/>	<input checked="" type="checkbox"/>	<input checked="" type="checkbox"/>	<input checked="" type="checkbox"/>	<input checked="" type="checkbox"/>	<input checked="" type="checkbox"/>	<input type="checkbox"/>	<input type="checkbox"/>	<input type="checkbox"/>	<input type="checkbox"/>	<input type="checkbox"/>	<input type="checkbox"/>	<input type="checkbox"/>	<input type="checkbox"/>
		<input checked="" type="checkbox"/>	<input checked="" type="checkbox"/>	<input checked="" type="checkbox"/>	<input checked="" type="checkbox"/>	<input checked="" type="checkbox"/>	<input checked="" type="checkbox"/>	<input checked="" type="checkbox"/>	<input checked="" type="checkbox"/>	<input type="checkbox"/>	<input type="checkbox"/>	<input type="checkbox"/>	<input type="checkbox"/>	<input type="checkbox"/>	<input type="checkbox"/>	<input type="checkbox"/>	<input type="checkbox"/>
		<input checked="" type="checkbox"/>	<input checked="" type="checkbox"/>	<input checked="" type="checkbox"/>	<input checked="" type="checkbox"/>	<input checked="" type="checkbox"/>	<input checked="" type="checkbox"/>	<input checked="" type="checkbox"/>	<input checked="" type="checkbox"/>	<input type="checkbox"/>	<input type="checkbox"/>	<input type="checkbox"/>	<input type="checkbox"/>	<input type="checkbox"/>	<input type="checkbox"/>	<input type="checkbox"/>	<input type="checkbox"/>
		<input checked="" type="checkbox"/>	<input checked="" type="checkbox"/>	<input checked="" type="checkbox"/>	<input checked="" type="checkbox"/>	<input checked="" type="checkbox"/>	<input checked="" type="checkbox"/>	<input checked="" type="checkbox"/>	<input checked="" type="checkbox"/>	<input type="checkbox"/>	<input type="checkbox"/>	<input type="checkbox"/>	<input type="checkbox"/>	<input type="checkbox"/>	<input type="checkbox"/>	<input type="checkbox"/>	<input type="checkbox"/>
		<input checked="" type="checkbox"/>	<input checked="" type="checkbox"/>	<input checked="" type="checkbox"/>	<input checked="" type="checkbox"/>	<input checked="" type="checkbox"/>	<input checked="" type="checkbox"/>	<input checked="" type="checkbox"/>	<input checked="" type="checkbox"/>	<input type="checkbox"/>	<input type="checkbox"/>	<input type="checkbox"/>	<input type="checkbox"/>	<input type="checkbox"/>	<input type="checkbox"/>	<input type="checkbox"/>	<input type="checkbox"/>
		<input checked="" type="checkbox"/>	<input checked="" type="checkbox"/>	<input checked="" type="checkbox"/>	<input checked="" type="checkbox"/>	<input checked="" type="checkbox"/>	<input checked="" type="checkbox"/>	<input checked="" type="checkbox"/>	<input checked="" type="checkbox"/>	<input type="checkbox"/>	<input type="checkbox"/>	<input type="checkbox"/>	<input type="checkbox"/>	<input type="checkbox"/>	<input type="checkbox"/>	<input type="checkbox"/>	<input type="checkbox"/>
		<input checked="" type="checkbox"/>	<input checked="" type="checkbox"/>	<input checked="" type="checkbox"/>	<input checked="" type="checkbox"/>	<input checked="" type="checkbox"/>	<input checked="" type="checkbox"/>	<input checked="" type="checkbox"/>	<input checked="" type="checkbox"/>	<input type="checkbox"/>	<input type="checkbox"/>	<input type="checkbox"/>	<input type="checkbox"/>	<input type="checkbox"/>	<input type="checkbox"/>	<input type="checkbox"/>	<input type="checkbox"/>
		<input checked="" type="checkbox"/>	<input checked="" type="checkbox"/>	<input checked="" type="checkbox"/>	<input checked="" type="checkbox"/>	<input checked="" type="checkbox"/>	<input checked="" type="checkbox"/>	<input checked="" type="checkbox"/>	<input checked="" type="checkbox"/>	<input type="checkbox"/>	<input type="checkbox"/>	<input type="checkbox"/>	<input type="checkbox"/>	<input type="checkbox"/>	<input type="checkbox"/>	<input type="checkbox"/>	<input type="checkbox"/>
		<input checked="" type="checkbox"/>	<input checked="" type="checkbox"/>	<input checked="" type="checkbox"/>	<input checked="" type="checkbox"/>	<input checked="" type="checkbox"/>	<input checked="" type="checkbox"/>	<input checked="" type="checkbox"/>	<input checked="" type="checkbox"/>	<input type="checkbox"/>	<input type="checkbox"/>	<input type="checkbox"/>	<input type="checkbox"/>	<input type="checkbox"/>	<input type="checkbox"/>	<input type="checkbox"/>	<input type="checkbox"/>
		<input checked="" type="checkbox"/>	<input checked="" type="checkbox"/>	<input checked="" type="checkbox"/>	<input checked="" type="checkbox"/>	<input checked="" type="checkbox"/>	<input checked="" type="checkbox"/>	<input checked="" type="checkbox"/>	<input checked="" type="checkbox"/>	<input type="checkbox"/>	<input type="checkbox"/>	<input type="checkbox"/>	<input type="checkbox"/>	<input type="checkbox"/>	<input type="checkbox"/>	<input type="checkbox"/>	<input type="checkbox"/>
		<input checked="" type="checkbox"/>	<input checked="" type="checkbox"/>	<input checked="" type="checkbox"/>	<input checked="" type="checkbox"/>	<input checked="" type="checkbox"/>	<input checked="" type="checkbox"/>	<input checked="" type="checkbox"/>	<input checked="" type="checkbox"/>	<input type="checkbox"/>	<input type="checkbox"/>	<input type="checkbox"/>	<input type="checkbox"/>	<input type="checkbox"/>	<input type="checkbox"/>	<input type="checkbox"/>	<input type="checkbox"/>
		<input checked="" type="checkbox"/>	<input checked="" type="checkbox"/>	<input checked="" type="checkbox"/>	<input checked="" type="checkbox"/>	<input checked="" type="checkbox"/>	<input checked="" type="checkbox"/>	<input checked="" type="checkbox"/>	<input checked="" type="checkbox"/>	<input type="checkbox"/>	<input type="checkbox"/>	<input type="checkbox"/>	<input type="checkbox"/>	<input type="checkbox"/>	<input type="checkbox"/>	<input type="checkbox"/>	<input type="checkbox"/>
		<input checked="" type="checkbox"/>	<input checked="" type="checkbox"/>	<input checked="" type="checkbox"/>	<input checked="" type="checkbox"/>	<input checked="" type="checkbox"/>	<input checked="" type="checkbox"/>	<input checked="" type="checkbox"/>	<input checked="" type="checkbox"/>	<input type="checkbox"/>	<input type="checkbox"/>	<input type="checkbox"/>	<input type="checkbox"/>	<input type="checkbox"/>	<input type="checkbox"/>	<input type="checkbox"/>	<input type="checkbox"/>
		<input checked="" type="checkbox"/>	<input checked="" type="checkbox"/>	<input checked="" type="checkbox"/>	<input checked="" type="checkbox"/>	<input checked="" type="checkbox"/>	<input checked="" type="checkbox"/>	<input checked="" type="checkbox"/>	<input checked="" type="checkbox"/>	<input type="checkbox"/>	<input type="checkbox"/>	<input type="checkbox"/>	<input type="checkbox"/>	<input type="checkbox"/>	<input type="checkbox"/>	<input type="checkbox"/>	<input type="checkbox"/>
		<input checked="" type="checkbox"/>	<input checked="" type="checkbox"/>	<input checked="" type="checkbox"/>	<input checked="" type="checkbox"/>	<input checked="" type="checkbox"/>	<input checked="" type="checkbox"/>	<input checked="" type="checkbox"/>	<input checked="" type="checkbox"/>	<input type="checkbox"/>	<input type="checkbox"/>	<input type="checkbox"/>	<input type="checkbox"/>	<input type="checkbox"/>	<input type="checkbox"/>	<input type="checkbox"/>	<input type="checkbox"/>
		<input checked="" type="checkbox"/>	<input checked="" type="checkbox"/>	<input checked="" type="checkbox"/>	<input checked="" type="checkbox"/>	<input checked="" type="checkbox"/>	<input checked="" type="checkbox"/>	<input checked="" type="checkbox"/>	<input checked="" type="checkbox"/>	<input type="checkbox"/>	<input type="checkbox"/>	<input type="checkbox"/>	<input type="checkbox"/>	<input type="checkbox"/>	<input type="checkbox"/>	<input type="checkbox"/>	<input type="checkbox"/>
		<input checked="" type="checkbox"/>	<input checked="" type="checkbox"/>	<input checked="" type="checkbox"/>	<input checked="" type="checkbox"/>	<input checked="" type="checkbox"/>	<input checked="" type="checkbox"/>	<input checked="" type="checkbox"/>	<input checked="" type="checkbox"/>	<input type="checkbox"/>	<input type="checkbox"/>	<input type="checkbox"/>	<input type="checkbox"/>	<input type="checkbox"/>	<input type="checkbox"/>	<input type="checkbox"/>	<input type="checkbox"/>
		<input checked="" type="checkbox"/>	<input checked="" type="checkbox"/>	<input checked="" type="checkbox"/>	<input checked="" type="checkbox"/>	<input checked="" type="checkbox"/>	<input checked="" type="checkbox"/>	<input checked="" type="checkbox"/>	<input checked="" type="checkbox"/>	<input type="checkbox"/>	<input type="checkbox"/>	<input type="checkbox"/>	<input type="checkbox"/>	<input type="checkbox"/>	<input type="checkbox"/>	<input type="checkbox"/>	<input type="checkbox"/>
		<input checked="" type="checkbox"/>	<input checked="" type="checkbox"/>	<input checked="" type="checkbox"/>	<input checked="" type="checkbox"/>	<input checked="" type="checkbox"/>	<input checked="" type="checkbox"/>	<input checked="" type="checkbox"/>	<input checked="" type="checkbox"/>	<input type="checkbox"/>	<input type="checkbox"/>	<input type="checkbox"/>	<input type="checkbox"/>	<input type="checkbox"/>	<input type="checkbox"/>	<input type="checkbox"/>	<input type="checkbox"/>
		<input checked="" type="checkbox"/>	<input checked="" type="checkbox"/>	<input checked="" type="checkbox"/>	<input checked="" type="checkbox"/>	<input checked="" type="checkbox"/>	<input checked="" type="checkbox"/>	<input checked="" type="checkbox"/>	<input checked="" type="checkbox"/>	<input type="checkbox"/>	<input type="checkbox"/>	<input type="checkbox"/>	<input type="checkbox"/>	<input type="checkbox"/>	<input type="checkbox"/>	<input type="checkbox"/>	<input type="checkbox"/>
		<input checked="" type="checkbox"/>	<input checked="" type="checkbox"/>	<input checked="" type="checkbox"/>	<input checked="" type="checkbox"/>	<input checked="" type="checkbox"/>	<input checked="" type="checkbox"/>	<input checked="" type="checkbox"/>	<input checked="" type="checkbox"/>	<input type="checkbox"/>	<input type="checkbox"/>	<input type="checkbox"/>	<input type="checkbox"/>	<input type="checkbox"/>	<input type="checkbox"/>	<input type="checkbox"/>	<input type="checkbox"/>
		<input checked="" type="checkbox"/>	<input checked="" type="checkbox"/>	<input checked="" type="checkbox"/>	<input checked="" type="checkbox"/>	<input checked="" type="checkbox"/>	<input checked="" type="checkbox"/>	<input checked="" type="checkbox"/>	<input checked="" type="checkbox"/>	<input type="checkbox"/>	<input type="checkbox"/>	<input type="checkbox"/>	<input type="checkbox"/>	<input type="checkbox"/>	<input type="checkbox"/>	<input type="checkbox"/>	<input type="checkbox"/>
		<input checked="" type="checkbox"/>	<input checked="" type="checkbox"/>	<input checked="" type="checkbox"/>	<input checked="" type="checkbox"/>	<input checked="" type="checkbox"/>	<input checked="" type="checkbox"/>	<input checked="" type="checkbox"/>	<input checked="" type="checkbox"/>	<input type="checkbox"/>	<input type="checkbox"/>	<input type="checkbox"/>	<input type="checkbox"/>	<input type="checkbox"/>	<input type="checkbox"/>	<input type="checkbox"/>	<input type="checkbox"/>
		<input checked="" type="checkbox"/>	<input checked="" type="checkbox"/>	<input checked="" type="checkbox"/>	<input checked="" type="checkbox"/>	<input checked="" type="checkbox"/>	<input checked="" type="checkbox"/>	<input checked="" type="checkbox"/>	<input checked="" type="checkbox"/>	<input type="checkbox"/>	<input type="checkbox"/>	<input type="checkbox"/>	<input type="checkbox"/>	<input type="checkbox"/>	<input type="checkbox"/>	<input type="checkbox"/>	<input type="checkbox"/>
		<input checked="" type="checkbox"/>	<input checked="" type="checkbox"/>	<input checked="" type="checkbox"/>	<input checked="" type="checkbox"/>	<input checked="" type="checkbox"/>	<input checked="" type="checkbox"/>	<input checked="" type="checkbox"/>	<input checked="" type="checkbox"/>	<input type="checkbox"/>	<input type="checkbox"/>	<input type="checkbox"/>	<input type="checkbox"/>	<input type="checkbox"/>	<input type="checkbox"/>	<input type="checkbox"/>	<input type="checkbox"/>
		<input checked="" type="checkbox"/>	<input checked="" type="checkbox"/>	<input checked="" type="checkbox"/>	<input checked="" type="checkbox"/>	<input checked="" type="checkbox"/>	<input checked="" type="checkbox"/>	<input checked="" type="checkbox"/>	<input checked="" type="checkbox"/>	<input type="checkbox"/>	<input type="checkbox"/>	<input type="checkbox"/>	<input type="checkbox"/>	<input type="checkbox"/>	<input type="checkbox"/>	<input type="checkbox"/>	<input type="checkbox"/>
		<input checked="" type="checkbox"/>	<input checked="" type="checkbox"/>	<input checked="" type="checkbox"/>	<input checked="" type="checkbox"/>	<input checked="" type="checkbox"/>	<input checked="" type="checkbox"/>	<input checked="" type="checkbox"/>	<input checked="" type="checkbox"/>	<input type="checkbox"/>	<input type="checkbox"/>	<input type="checkbox"/>	<input type="checkbox"/>	<input type="checkbox"/>	<input type="checkbox"/>	<input type="checkbox"/>	<input type="checkbox"/>
		<input checked="" type="checkbox"/>	<input checked="" type="checkbox"/>	<input checked="" type="checkbox"/>	<input checked="" type="checkbox"/>	<input checked="" type="checkbox"/>	<input checked="" type="checkbox"/>	<input checked="" type="checkbox"/>	<input checked="" type="checkbox"/>	<input type="checkbox"/>	<input type="checkbox"/>	<input type="checkbox"/>	<input type="checkbox"/>	<input type="checkbox"/>	<input type="checkbox"/>	<input type="checkbox"/>	<input type="checkbox"/>
		<input checked="" type="checkbox"/>	<input checked="" type="checkbox"/>	<input checked="" type="checkbox"/>	<input checked="" type="checkbox"/>	<input checked="" type="checkbox"/>	<input checked="" type="checkbox"/>	<input checked="" type="checkbox"/>	<input checked="" type="checkbox"/>	<input type="checkbox"/>	<input type="checkbox"/>	<input type="checkbox"/>	<input type="checkbox"/>	<input type="checkbox"/>	<input type="checkbox"/>	<input type="checkbox"/>	<input type="checkbox"/>
		<input checked="" type="checkbox"/>	<input checked="" type="checkbox"/>	<input checked="" type="checkbox"/>	<input checked="" type="checkbox"/>	<input checked="" type="checkbox"/>	<input checked="" type="checkbox"/>	<input checked="" type="checkbox"/>	<input checked="" type="checkbox"/>	<input type="checkbox"/>	<input type="checkbox"/>	<input type="checkbox"/>	<input type="checkbox"/>	<input type="checkbox"/>	<input type="checkbox"/>	<input type="checkbox"/>	<input type="checkbox"/>
		<input checked="" type="checkbox"/>	<input checked="" type="checkbox"/>	<input checked="" type="checkbox"/>	<input checked="" type="checkbox"/>	<input checked="" type="checkbox"/>	<input checked="" type="checkbox"/>	<input checked="" type="checkbox"/>	<input checked="" type="checkbox"/>	<input type="checkbox"/>	<input type="checkbox"/>	<input type="checkbox"/>	<input type="checkbox"/>	<input type="checkbox"/>	<input type="checkbox"/>	<input type="checkbox"/>	<input type="checkbox"/>
		<input checked="" type="checkbox"/>	<input checked="" type="checkbox"/>	<input checked="" type="checkbox"/>	<input checked="" type="checkbox"/>	<input checked="" type="checkbox"/>	<input checked="" type="checkbox"/>	<input checked="" type="checkbox"/>	<input checked="" type="checkbox"/>	<input type="checkbox"/>	<input type="checkbox"/>	<input type="checkbox"/>	<input type="checkbox"/>	<input type="checkbox"/>	<input type="checkbox"/>	<input type="checkbox"/>	<input type="checkbox"/>
		<input checked="" type="checkbox"/>	<input checked="" type="checkbox"/>	<input checked="" type="checkbox"/>	<input checked="" type="checkbox"/>	<input checked="" type="checkbox"/>	<input checked="" type="checkbox"/>	<input checked="" type="checkbox"/>	<input checked="" type="checkbox"/>	<input type="checkbox"/>	<input type="checkbox"/>	<input type="checkbox"/>	<input type="checkbox"/>	<input type="checkbox"/>	<input type="checkbox"/>	<input type="checkbox"/>	<input type="checkbox"/>
		<input checked="" type="checkbox"/>	<input checked="" type="checkbox"/>	<input checked="" type="checkbox"/>	<input checked="" type="checkbox"/>	<input checked="" type="checkbox"/>	<input checked="" type="checkbox"/>	<input checked="" type="checkbox"/>	<input checked="" type="checkbox"/>	<input type="checkbox"/>	<input type="checkbox"/>	<input type="checkbox"/>	<input type="checkbox"/>	<input type="checkbox"/>	<input type="checkbox"/>	<input type="checkbox"/>	<input type="checkbox"/>
		<input checked="" type="checkbox"/>	<input checked="" type="checkbox"/>	<input checked="" type="checkbox"/>	<input checked="" type="checkbox"/>	<input checked="" type="checkbox"/>	<input checked="" type="checkbox"/>	<input checked="" type="checkbox"/>	<input checked="" type="checkbox"/>	<input type="checkbox"/>	<input type="checkbox"/>	<input type="checkbox"/>	<input type="checkbox"/>	<input type="checkbox"/>	<input type="checkbox"/>	<input type="checkbox"/>	<input type="checkbox"/>
		<input checked="" type="checkbox"/>	<input checked="" type="checkbox"/>	<input checked="" type="checkbox"/>	<input checked="" type="checkbox"/>	<input checked="" type="checkbox"/>	<input checked="" type="checkbox"/>	<input checked="" type="checkbox"/>	<input checked="" type="checkbox"/>	<input type="checkbox"/>	<input type="checkbox"/>	<input type="checkbox"/>	<input type="checkbox"/>	<input type="checkbox"/>	<input type="checkbox"/>	<input type="checkbox"/>	<input type="checkbox"/>
		<input checked="" type="checkbox"/>	<input checked="" type="checkbox"/>	<input checked="" type="checkbox"/>	<input checked="" type="checkbox"/>	<input checked="" type="checkbox"/>	<input checked="" type="checkbox"/>	<input checked="" type="checkbox"/>	<input checked="" type="checkbox"/>	<input type="checkbox"/>	<input type="checkbox"/>	<input type="checkbox"/>	<input type="checkbox"/>	<input type="checkbox"/>	<input type="checkbox"/>	<input type="checkbox"/>	<input type="checkbox"/>
		<input checked="" type="checkbox"/>	<input checked="" type="checkbox"/>	<input checked="" type="checkbox"/>	<input checked="" type="checkbox"/>	<input checked="" type="checkbox"/>	<input checked="" type="checkbox"/>	<input checked="" type="checkbox"/>	<input checked="" type="checkbox"/>	<input type="checkbox"/>	<input type="checkbox"/>	<input type="checkbox"/>	<input type="checkbox"/>	<input type="checkbox"/>	<input type="checkbox"/>	<input type="checkbox"/>	<input type="checkbox"/>
		<input checked="" type="checkbox"/>	<input checked="" type="checkbox"/>	<input checked="" type="checkbox"/>	<input checked="" type="checkbox"/>	<input checked="" type="checkbox"/>	<input checked="" type="checkbox"/>	<input checked="" type="checkbox"/>	<input checked="" type="checkbox"/>	<input type="checkbox"/>	<input type="checkbox"/>	<input type="checkbox"/>	<input type="checkbox"/>	<input type="checkbox"/>	<input type="checkbox"/>	<input type="checkbox"/>	<input type="checkbox"/>
		<input checked="" type="checkbox"/>	<input checked="" type="checkbox"/>	<input checked="" type="checkbox"/>	<input checked="" type="checkbox"/>	<input checked="" type="checkbox"/>	<input checked="" type="checkbox"/>	<input checked="" type="checkbox"/>	<input checked="" type="checkbox"/>	<input type="checkbox"/>	<input type="checkbox"/>	<input type="checkbox"/>	<input type="checkbox"/>	<input type="checkbox"/>	<input type="checkbox"/>	<input type="checkbox"/>	<input type="checkbox"/>
		<input checked="" type="checkbox"/>	<input checked="" type="checkbox"/>	<input checked="" type="checkbox"/>	<input checked="" type="checkbox"/>	<input checked="" type="checkbox"/>	<input checked="" type="checkbox"/>	<input checked="" type="checkbox"/>	<input checked="" type="checkbox"/>	<input type="checkbox"/>	<input type="checkbox"/>	<input type="checkbox"/>	<input type="checkbox"/>	<input type="checkbox"/>	<input type="checkbox"/>	<input type="checkbox"/>	<input type="checkbox"/>
		<input checked="" type="checkbox"/>	<input checked="" type="checkbox"/>	<input checked="" type="checkbox"/>	<input checked="" type="checkbox"/>	<input checked="" type="checkbox"/>	<input checked="" type="checkbox"/>	<input checked="" type="checkbox"/>	<input checked="" type="checkbox"/>	<input type="checkbox"/>	<input type="checkbox"/>	<input type="checkbox"/>	<input type="checkbox"/>	<input type="checkbox"/>	<input type="checkbox"/>	<input type="checkbox"/>	<input type="checkbox"/>
		<input checked="" type="checkbox"/>	<input checked="" type="checkbox"/>	<input checked="" type="checkbox"/>	<input checked="" type="checkbox"/>	<input checked="" type="checkbox"/>	<input checked="" type="checkbox"/>	<input checked="" type="checkbox"/>	<input checked="" type="checkbox"/>	<input type="checkbox"/>	<input type="checkbox"/>	<input type="checkbox"/>	<input type="checkbox"/>	<input type="checkbox"/>	<input type="checkbox"/>	<input type="checkbox"/>	<input type="checkbox"/>
		<input checked="" type="checkbox"/>	<input checked="" type="checkbox"/>	<input checked="" type="checkbox"/>	<input checked="" type="checkbox"/>	<input checked="" type="checkbox"/>	<input checked="" type="checkbox"/>	<input checked="" type="checkbox"/>	<input checked="" type="checkbox"/>	<input type="checkbox"/>	<input type="checkbox"/>	<input type="checkbox"/>	<input type="checkbox"/>	<input type="checkbox"/>	<input type="checkbox"/>	<input type="checkbox"/>	<input type="checkbox"/>
		<input checked="" type="checkbox"/>	<input checked="" type="checkbox"/>	<input checked="" type="checkbox"/>	<input checked="" type="checkbox"/>	<input checked="" type="checkbox"/>	<input checked="" type="checkbox"/>	<input checked="" type="checkbox"/>	<input checked="" type="checkbox"/>	<input type="checkbox"/>	<input type="checkbox"/>	<input type="checkbox"/>	<input type="checkbox"/>	<input type="checkbox"/>	<input type="checkbox"/>	<input type="checkbox"/>	<input type="checkbox"/>
		<input checked="" type="checkbox"/>	<input checked="" type="checkbox"/>	<													

14. Each bit set to ON in the AIO Panel should output a logic-high signal at the corresponding I/O terminal, corresponding typically to 4 volts (minimum of 2.2 volts) at a DMM/DVM. Each bit set to OFF in the AIO Panel should output a logic-low signal at the corresponding I/O terminal, corresponding typically to 0 volts (maximum of 0.8 volts) at a DMM/DVM. Do one of the following:
 - If the bit patterns set on the AIO Panel do not agree with the logic levels measured at the I/O terminals, the board is not functioning properly. Stop here, and return to the step in the “[General problem isolation procedure](#)” where you were directed to do I/O bit tests (step 17 or step 26e in the “[General problem isolation procedure](#)”).
 - If the bit patterns set on the AIO Panel agree with the logic levels measured at the I/O terminals, then continue with step 15.
15. In the **Digital Output Panel** under **Channels**, click on channel **0** as shown as shown in [Figure 5-15](#).

Figure 5-15
Configuring channel 1 for output bit pattern B

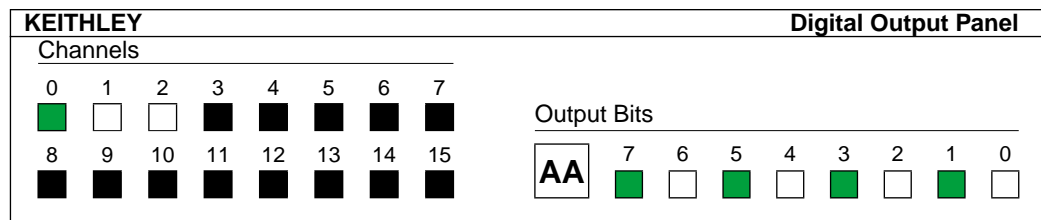

16. In the **Digital Output Panel** under **Output Bits**, set the bits of channel **0** for bit pattern B as shown in [Figure 5-15](#).
17. Repeat steps 15 and 16 for channels 1 and 2.
18. Again, do one of the following:
 - Measure the voltage between signal ground and each bit of ports A, B, and C with a DMM or DVM. Make measurements at the STA-50 terminals or the cabled mating connector that is connected to the selected CONN-3160-D1 50-pin connector.
 - Check the logic level for each bit of ports A, B, and C bit with a TTL logic probe. Make measurements at the STA-50 terminals or the cabled mating connector that is connected to the selected CONN-3160-D1 50-pin connector.
19. Again, each bit set to ON in the AIO Panel should output a logic-high signal at the corresponding I/O terminal, corresponding typically to 4 volts (minimum of 2.2 volts) at a DMM/DVM. Each bit set to OFF in the AIO Panel should output a logic-low signal at the corresponding I/O terminal, corresponding typically to 0 volts (maximum of 0.8 volts) at a DMM/DVM.
 - If the bit patterns set on the AIO Panel do not agree with the logic levels measured at the I/O terminals, the board is not functioning properly. Stop here, and return to the step in the “[General problem isolation procedure](#)” where you were directed to do I/O bit tests (step 17 or step 26e in the “[General problem isolation procedure](#)”).
 - If the bit patterns set on the AIO Panel do agree with the logic levels measured at the I/O terminals, but you have not performed an output set test for all four port groups, then repeat steps 2 through 14 for the next port group.
 - If the bit patterns set on the AIO Panel do agree with the logic levels measured at the I/O terminals, and you have performed an output set test for all four port groups, the board is functioning properly. Stop here, and return to the step in the “[General problem isolation procedure](#)” where you were directed to do I/O bit tests (step 17 or step 26e in the “[General problem isolation procedure](#)”). Or, optionally, perform the I/O loop-back test, as discussed in the previous subsection, if you have not already done so.

Technical support

Before returning any equipment for repair, call Keithley for technical support at:

1-888-KEITHLEY

Monday - Friday, 8:00 a.m. - 5:00 p.m., Eastern Time

An applications engineer will help you diagnose and resolve your problem over the telephone. Please make sure that you have the following information available before you call:

KPCI-3160 board configuration	Model	_____
	Serial #	_____
	Revision code	_____
	Interrupt level setting	_____
	Number of channels	_____
Computer	Manufacturer	_____
	CPU type	_____
	Clock speed (MHz)	_____
	MB of RAM	_____
	Video system	_____
	BIOS type	_____
Operating system	Windows version	_____
Software package	Name	_____
	Serial #	_____
	Version	_____
	Invoice/Order #	_____
Compiler (if applicable)	Language	_____
	Manufacturer	_____
	Version	_____
Accessories	Type	_____
	Type	_____
	Type	_____
	Type	_____
	Type	_____
	Type	_____
	Type	_____

If a telephone resolution is not possible, the applications engineer will issue you a Return Material Authorization (RMA) number and ask you to return the equipment. Include the RMA number with any documentation regarding the equipment.

When returning equipment for repair, include the following information:

- Your name, address, and telephone number.
- The invoice or order number and date of equipment purchase.
- A description of the problem or its symptoms.
- The RMA number on the **outside** of the package.

Repackage the equipment, using the original anti-static wrapping, if possible, and handle it with ground protection. Ship the equipment to:

ATTN: RMA # _____
Repair Department
Keithley Instruments, Inc.
28775 Aurora Road
Cleveland, Ohio 44139

Telephone 1-888-KEITHLEY
FAX (440) 248-6168

NOTE

If you are submitting your equipment for repair under warranty, you must include the invoice number and date of purchase.

To enable Keithley to respond as quickly as possible, you must include the RMA number on the outside of the package.

A Specifications

Logic Inputs and Outputs

SYMBOL	PARAMETER	MIN.	TYP.	MAX.	UNIT
V _{IH}	Voltage, Input High	2.0	—	—	V
V _{IL}	Voltage, Input Low	—	—	0.8	V
I _{IH}	Current, Input High, V _{IN} = 2.7V	—	—	±1	μA
I _{IL}	Current, Input Low, V _{IN} = 0.5 V	—	—	±1	μA
I _{OZH}	High Impedance Output Current, V _{OUT} High	—	—	±1	μA
I _{OZL}	High Impedance Output Current, V _{OUT} Low	—	—	±1	μA
V _{OH}	Voltage, Output High, I _{OH} = -8 mA	2.4	3.3	—	V
V _{OL}	Voltage, Output Low, I _{OL} = -15 mA	2.0	3.0	—	V
V _{OL}	Voltage, Output Low, I _{OL} = 64 mA	—	0.3	0.55	V
I _{OL}	Current, Output Low	—	—	64.0	mA
I _{OH}	Current Output High	—	—	-15	mA
I _{OS}	Short Circuit Current	-60.0	-120.0	-225.0	mA
I _{OFF}	Input/Output Power off leakage	—	—	±1	μA

Digital I/O

Each channel of the KPCI-3160 may be fully loaded provided the total sourcing current does not exceed the ratings of the KPCI-3160 and accessories/circuits used, i.e. each channel of Port A may simultaneously source 15mA for a total of 120mA with no risk of output driver overheating. Details of current capability via on-board power is discussed below.

Power Available To External Circuits

The KPCI-3160 provides current limited power available to external circuits via the 100 pin connector. The locations and requirements are summarized below.

KPCI-3160 PIN #	PARAMETER	MIN.	TYP.	MAX.	UNIT
1	+5 Volts	—	—	1.0	A
50	GND Return	—	0.0	—	V
51	+5 Volts	—	—	1.0	A
100	GND Return	—	0.0	—	V

Current drawn from pin pair #1 and #50 should not exceed 1.0A. Similarly, current drawn from pin pair #51 and #100 should not exceed 1.0A. Total current available to drive external circuits is limited to 2.0A. This power is supplied by the PC power supply.

Assuming power supply of +5VDC and full loading (2A), the KPCI-3160 requires a maximum of 10.5W of power.

Board Address Mapping

No jumper placed on REG-MAP-SEL yields register map A. (DEFAULT)

There are 4 data groups with 4 control bytes. Each control byte is part of the corresponding 32 bit data word.

FORMAT: Control/Data register: (MSB)[Control Byte X][Port C][Port B][Port A](LSB)

Base Address 1 + Offset 0x00	Group 0 Data	Read/Write
Base Address 1 + Offset 0x04	Group 1 Data	Read/Write
Base Address 1 + Offset 0x08	Group 2 Data	Read/Write
Base Address 1 + Offset 0x0C	Group 3 Data	Read/Write

Control Byte X Format REG MAP A:

Bit 7 - This bit to be ignored.

Bit 6 - Access Mode Select - For B5 and B6. See table below.

Bit 5 - Access Mode Select - For B5 and B6. See table below.

Bit 4 - PAX_DIR - Port A I/O direction, 1-input, 0-output

Bit 3 - PCHIX_DIR - Port C HI I/O direction, 1-input, 0-output

Bit 2 - This bit to be ignored.

Bit 1 - PBX_DIR - Port B I/O direction, 1-input, 0-output

Bit 0 - PCLOX_DIR - Port C LO I/O direction, 1-input, 0-output

B6	B5	
0	0	No input latching.
0	1	Latch group inputs on rising interrupt edge.
1	0	No input latching.
1	1	Latch group inputs on falling interrupt edge.

This emulates the 8255A standard.

Emulation of AMCC S5933 Interrupt Control/Status Register(INT_CSR)

Base Address 0 + Offset 0x38	Interrupt Status Register	Read/Write
------------------------------	---------------------------	------------

Interrupt Status Register Format:

Bit 23 Interrupt missed = 1 for missed interrupt. Write 1 to acknowledge/clear.

Bit 17 Interrupt pending = 1 for pending interrupt. Write 1 to acknowledge/clear.

Bit 12 Interrupt enable = 1, HW Interrupts enabled, 0 = HW Interrupts disabled.

Bit 06 Interrupt polarity select = 1 for falling edge, Write 0 for rising edge.

Base Address 0 + 0x34 (32 Bit Read) = ASCII "A" "0" "x" "x" - Firmware Revision.

KPCI-3160 100-Pin Connector

3160 Data Group 0		3160 Data Group 1		3160 Data Group 2		3160 Data Group 3	
Pin #	Signal	Pin #	Signal	Pin #	Signal	Pin #	Signal
76	PA0	26	PA0	52	PA0	02	PA0
77	PA1	27	PA1	53	PA1	03	PA1
78	PA2	28	PA2	54	PA2	04	PA2
79	PA3	29	PA3	55	PA3	05	PA3
80	PA4	30	PA4	56	PA4	06	PA4
81	PA5	31	PA5	57	PA5	07	PA5
82	PA6	32	PA6	58	PA6	08	PA6
83	PA7	33	PA7	59	PA7	09	PA7
84	PB0	34	PB0	60	PB0	10	PB0
85	PB1	35	PB1	61	PB1	11	PB1
86	PB2	36	PB2	62	PB2	12	PB2
87	PB3	37	PB3	63	PB3	13	PB3
88	PB4	38	PB4	64	PB4	14	PB4
89	PB5	39	PB5	65	PB5	15	PB5
90	PB6	40	PB6	66	PB6	16	PB6
91	PB7	41	PB7	67	PB7	17	PB7
92	PC0	42	PC0	68	PC0	18	PC0
93	PC1	43	PC1	69	PC1	19	PC1
94	PC2	44	PC2	70	PC2	20	PC2
95	PC3	45	PC3	71	PC3	21	PC3
96	PC4	46	PC4	72	PC4	22	PC4
97	PC5	47	PC5	73	PC5	23	PC5
98	PC6	48	PC6	74	PC6	24	PC6
99	PC7	49	PC7	75	PC7	25	PC7

General

POWER REQUIREMENTS: +5V, 0.07A min.
+5V, 1.5A typ.
+5V, 2.1A max.

EMC: Conforms to European Union Directive 89/336/EEC.

SAFETY: Meets EN61010-1/IEC 1010.

ENVIRONMENTAL:

Operating Temperature: 0° to 70°C

Storage Temperature: -40° to 100°C

Humidity (non condensing): 0 to 90%.

DIMENSION, WEIGHT: 127mm long × 108mm wide × 19mm high (5" × 4.25" × 0.75") (half slot). Net weight 125g (4.4 oz).

Specifications subject to change without notice.

B

I/O Address Mapping

NOTE *A typical user of the KPCI-3160 board does not need to read this appendix (except perhaps for the supplementary interrupt illustration under “Interrupt example scenario”). Register level programming of the KPCI-3160 board is neither practical nor necessary for most users. Register level interfacing with the PCI bus is more complex than with the ISA bus. PCI board addresses are mapped automatically in I/O space or memory, whereas ISA board addresses are assigned manually by the user in I/O space.*

However, under Windows 95/98 only, you may be able to reuse an existing port I/O application program—if it was designed to work with the industry-standard 8255 and 82C55 chips—by substituting the automatically-mapped address for the user-assigned address. Refer to “Using existing port I/O software to manipulate control and data registers” at the end of Appendix B.

The DriverLINX driver shipped with your board provides a user-friendly Application Programming Interface (API) that supports Visual C++, Visual Basic, and Delphi programming languages under Windows 95/98 and Windows NT 4.0. You are encouraged to use the capabilities of DriverLINX and ignore the rest of the information in this chapter (except perhaps the subsection “Interrupt example scenario,” which may help you to understand how external interrupts work).

However, there are circumstances in which advanced users may desire or need to bypass DriverLINX entirely and write their own drivers. Alternatively, advanced users may wish to program the KPCI-3160 at the register level using an ActiveX hosting language. Finally, some users may wish to reuse an existing application program that makes port I/O calls to an ISA-bus digital I/O board.

Appendix B discusses the following:

- General PCI address assignments
- Control and data register address assignments inside the I/O space, as follows:
 - Assignments for a control and data register map that emulates the assignments of the 8255 and 82C55 chips
 - Assignments for five bits of a special interrupt control/status register, including an example scenario showing how the bits are used
- Some general requirements for manipulating control and data registers
- Reuse of an existing port I/O application program with the KPCI-3160 board

General PCI address assignments

The PCI specification allows each PCI-bus board to be assigned up to five distinct address regions for general use at the discretion of the hardware designer. The first region, at base address BADDR0, is mandatory per the PCI specification, as published by the PCI Special Interest Group (PCISIG). The other four address regions, located at base addresses BADDR1, BADDR2, BADDR3, and BADDR4, are optional. The PCI BIOS or the Plug and Play operating system automatically allocates BADDR0 through BADDR4 at power-up, based on the PCI boards that it finds installed at that time. After power-up, computer software can read PCI configuration space to determine the location of BADDR0 through BADDR4. (The term “computer software” hereafter in Appendix B refers to the combination of the application programming interface (API)/driver—normally, DriverLINX—and the application program. For information about application programming through DriverLINX, refer to your DriverLINX documentation.)

The KPCI-3160 uses BADDR0 and BADDR1 mapped in I/O space. These addresses are usable only in the programmed I/O mode (register access through the CPU).

Register assignments

The KPCI-3160 registers are mapped in I/O space as follows:

- It uses locations offset from BADDR1 for its port I/O control and data registers
- It uses a location offset from BADDR0 (BADDR0 + 0x38) for a special interrupt control/status register (The prefix 0x designates hexadecimal.)

It uses Base Address 0 + 0x34 for the firmware revision: 32-bit ASCII "A0xx."

All offsets from the base address are specified as multiples of four bytes (modulo 4 addressing), because each offset specifies a four-byte (32-bit) wide register.

NOTE *The term "base" address, as used in the following subsections, does not have the same meaning for a PCI board, such as the KPCI-3160, as for an ISA board. The base address for your KPCI-3160 board is an address BADDR1 that is mapped in I/O space or memory and is assigned at power-up by the PCI BIOS or the Plug and Play operating system. It remains constant only as long as the computer is powered. It is not a fixed, user-assigned I/O address such as 0x300 or 0x310 set on a DIP switch, nor is it a fixed address such as is assigned for a printer.*

Control and data registers

The control and data register map emulates the register map of the 8255A standard, for the 8255 and 82C55 chips in mode 0, with some additional features to implement interrupt control and latching. The KPCI-3160 separates its 96 I/O lines into four port groups (0 through 3). Therefore, each port group has 24 I/O lines, which are divided into three 8-bit ports (A, B and C).

The data bits and control bits of each of the four port groups occupy a single 32-bit register. For each port group, the register bits are assigned as follows:

Bits of each control and data register	31.....24	23.....16	15.....8	7.....0
Contents	Control port	Port C	Port B	Port A

In the 8255 and 82C55 chips, the contents of data and control registers must be transferred eight bits at a time. However, in the KPCI-3160 the contents of data and control registers may be transferred either 8 bits or 32 bits at a time.

Control and data register addressing

The four I/O port groups use a total of four combined data-plus-control registers. The address of each register is offset from BADDR1 at a separate 32-bit boundary. Refer to [Table B-1](#); the prefix “0x” in [Table B-1](#) designates hexadecimal.

Table B-1

Data and control register addresses

Address	Contents	I/O Function
BADDR1 + 0x0 offset	Port group ¹ 0 data and control register bits	Read/Write for data. Read/Write for control registers.
BADDR1 + 0x4 offset	Port group 1 data and control register bits	
BADDR1 + 0x8 offset	Port group 2 data and control register bits	
BADDR1 + 0xC offset	Port group 3 data and control register bits	

¹Each port group contains a PA port, a PB port and a PC port, as in the emulated 8255 and 82C55 chips.

Control and data register control bit functions

The control register bit functions for each port group (port group 0 through port group 3) are identical. These functions are listed in [Table B-2](#).

Table B-2

Control register bit functions for each port group

Bit Number	Function	Variable Name	I/O Status for this Bit ¹	
			When Bit Value = 0	When Bit Value = 1
Bit 7	Not used	N/A	N/A	N/A
Bit 4	I/O direction for PA port	PA _x _DIR ³	Outputs, all bits of this port.	Inputs, all bits of this port.
Bit 3	I/O direction for PC port, upper half	PCHI _x _DIR ³	Outputs, all bits of this port.	Inputs, all bits of this port.
Bit 2	Not used	N/A	N/A	N/A
Bit 1	I/O direction for PB port	PB _x _DIR ³	Outputs, all bits of this port.	Inputs, all bits of this port.
Bit 0	I/O direction for PC port, lower half	PCLO _x _DIR ³	Outputs, all bits of this port.	Inputs, all bits of this port.

Bit Number	Function	Variable Name	I/O Status for this Bit ¹	
			Bit 6	Bit 5
Bit 6	Access Mode Select	N/A	0 0 = No input latching. 0 1 = Latch group on rising edge of INT_REQ signal. ² 1 0 = No input latching. 1 1 = Latch group on falling edge of INT_REQ signal. ²	
Bit 5	Access Mode Select	N/A		

¹ For safety, the values of bits 0, 1, 3, and 4 default to “1” upon computer reset or power-up, so that all ports start out as inputs.

² If control bit 6 is set to “0” for one or more port groups and is set to “1” for the remaining port groups, all port groups are configured for both rising (positive) edge and falling (negative) edge interrupt polarity.

³ x = port group number: 0, 1, 2 or 3.

Interrupt control/status register

The firmware of the KPCI-3160 board implements a 32-bit interrupt control/status register. This register is located at BADDR0 + 0x38 offset, where 0x designates hexadecimal. A control bit of the interrupt control/status register is used to configure the board for interrupt-based data transfer and processing. Two status bits are used to determine whether one or more interrupts are pending or were missed during data processing. Two control bits provide for the selection of interrupt polarity (falling or rising edge) and the enabling/disabling of the interrupt signal.

Interrupt control/status bit descriptions

The four interrupt control/status register bits are described in detail in [Table B-3](#).

Table B-3

Bit functions for interrupt control/status register

Interrupt Control/Status Register Bit			Status for this Bit ¹	
Bit Number	Bit Function	Where the Bit is Set and Cleared	When the Bit Value = 0	When the Bit Value = 1
Bit 06	Selects polarity for the external interrupt signal.	Set and cleared by computer software.	Sets rising edge for external interrupt signal.	Sets falling edge for external interrupt signal.
Bit 12	Configures the board for external interrupt service.	Set and cleared by computer software.	Interrupts disabled. Data transfer and processing via polling or upon software command, only. All inputs are general purpose inputs.	Interrupts enabled. Data transfer and processing in response to an external signal, only. The highest two inputs of port group 3 are INT_REQ and INT_ENN instead of PC6 and PC7.
Bit 17	Interrupt-pending. Indicates whether or not an external interrupt signal has been received at the board INT_REQ input.	Automatically set high when board firmware detects an interrupt. Must acknowledge (write 1) to clear.	Register status awaits detection of interrupt signal by firmware. Computer CPU is presently doing other tasks (not processing KPCI-3160 data).	Interrupt signal has been received. Computer CPU is processing, or is about to process, KPCI-3160 data via an ISR. ³
Bit 23	Interrupt-missed. Indicates whether or not at least one KPCI-3160 external interrupt signal has been sent and missed while interrupt-pending bit 17 is high.	Automatically set high when board firmware detects missed interrupt. ² Must acknowledge (write 1) to clear.	Interrupts have not been missed OR register status awaits missed-interrupt detection by firmware. ¹	One or more interrupts have been missed. ³

¹ All bits listed in this table are cleared to logic-low on power-up.

² Although this bit has both software read and software write capability, computer software writes should only be used to *clear* the bit.

³ This status is correct only if bit 17 is deliberately cleared by computer software at the conclusion of each KPCI-3160 ISR (each ISR that is used to process KPCI-3160 data).

Interrupt example scenario

The following example is one possible scenario that may help you to understand and use the KPCI-3160 interrupt feature. (This example is simplified, and some details may not apply to your specific system or to your requirements.) It illustrates the workings of the interrupts and bits 6, 12, 17, and 23 of the interrupt control/status register. (Refer also to [Section 4](#), “External Interrupts.”)

1. At some point, computer software sets interrupt-enable bit 12 of the interrupt control/status register to logic-high. (The term “software” here refers to the combination of the application programming interface (API)/driver—normally, DriverLINUX—and the application program. To understand how to program interrupt-triggered data acquisition through DriverLINUX, refer to your DriverLINUX documentation.) This status, detected by board firmware, enables the board to process data using external interrupts. It changes general-purpose inputs PC6 and PC7 of port group 3 into external interrupt request and external interrupt enable inputs INT_REQ and INT_ENN.
 2. At some point, computer software sets latching polarity bit 6 for port group 0 to determine whether that data at port group 0 latches on the rising or falling edge of INT_REQ. This action is repeated for port groups 1, 2, and 3.
 3. Prior to sending data, a user circuit sets INT_ENN to logic low. Board firmware detects that INT_ENN is low and allows the edges of interrupt signals at INT_REQ to be detected.
 4. When data is ready to be transferred and processed, the user circuit sends an external interrupt request signal to INT_REQ.
 5. Board firmware detects the rising or falling edge of the INT_REQ signal, depending on interrupt polarity settings in the port-group control registers ([Table B-2](#)).
 6. Software sets bit 6 of the interrupt control/status register high or low depending on whether the user wants a PCI interrupt to be triggered by the falling or rising edge of INT_REQ.
 7. If inputs are configured to latch, board firmware latches these input ports. (See bits 5 and 6 in [Table B-2](#).)
 8. The interrupt-received status in board firmware causes interrupt-pending bit 17 of the interrupt control/status register to be set to logic high.
 9. The interrupt-received status in board firmware causes a computer CPU interrupt to start, stopping execution of the current CPU task.
 10. Computer hardware detects an interrupt request signal and transfers control to an interrupt service routine (ISR).
 11. Computer software starts the ISR, which takes control of the CPU and starts processing the KPCI-3160 input data.
 12. The ISR proceeds.
 13. Ideally, for a well-planned data acquisition session, both of the following conditions are met while the ISR is in progress and the interrupt-pending bit is set:
 - No new external interrupt requests occur during this time.
 - If the board is set to detect both the rising and falling edges of an interrupt request signal, AND the rising edge started the ISR, then the falling edge does not occur during this time.
- However if either or both of the above conditions are not met while the interrupt-pending bit is set, the following occurs:
- a. The rising and/or falling edges of interrupt signals have no effect; these interrupts are missed.

- b. When the *first* rising or falling edge is missed, the problem is recorded as follows:
 1. Board firmware detects the missed interrupt, causing interrupt-missed bit 23 of the interrupt control/status register to be set to logic high.
 2. Computer software, if appropriately programmed, detects that bit 23 has been set and notifies the user of the missed interrupt.
- c. If *additional* rising or falling edges are missed (edges 2, 3,, n), the problems are *not* recorded, as follows:
 1. No additional interrupt-missed bits are set (there is only one interrupt-missed bit).
 2. Computer software cannot further notify the user.
14. The ISR, if appropriately programmed, writes ones (Acknowledge) to clear the interrupt-pending bit 17 and interrupt-missed bit 23 in the interrupt control/status register to logic low, which clears interrupt-pending status and interrupt-missing status in board firmware.
15. The ISR, if appropriately programmed, clears the rising/falling edge of bit 6 in the interrupt control/status register to logic low.
16. The ISR finishes.
17. The ISR dispatcher of the operating system detects that the ISR has finished and sends an end-of-interrupt instruction to the CPU.

NOTE *The end-of-ISR behavior depends on the operating system being used.*

18. The CPU returns to the task that it was executing at the time of the interrupt.
19. At some point, the user circuit may disable interrupts and latching by setting INT_ENN to logic high.
20. Board firmware detects that INT_ENN is high and rejects interrupt signals at INT_REQ.

Manipulating control and data registers

Be aware that software programming for a PCI board, such as the KPCI-3160, is more involved than for an ISA board. As mentioned in the Appendix B introduction, DriverLINX eliminates the need for user interaction with control and data registers. However, control and data registers can be manipulated in the following special situations:

- You are an advanced user needing to use the KPCI-3160 with an operating system other than Microsoft Windows 95/98 or Windows NT 4.0 or greater. In this situation, you must write a new driver. This task requires an in-depth knowledge of PCI-bus interfacing and your development operating system.
- You want to program the KPCI-3160 at the register level using an ActiveX hosting language. In this situation, you may use the “Direct I/O ActiveX Automation Object” that comes with DriverLINX. The Direct I/O ActiveX Automation Object allows you to set the control and data registers directly and bypass the DriverLINX API, yet avoids the full complexities of PCI bus interfacing. Refer to your DriverLINX manual for more information.
- You want to reuse, with the KPCI-3160, an existing application program that makes port I/O calls to an ISA-bus digital I/O board such as the PIO-96 or PIO-24. (If so, skip to “[Using existing port I/O software to manipulate control and data registers](#)” at the end of Appendix B.)

General approach to manipulating control and data registers

This subsection outlines some general program tasks needed to use the data and control registers of the KPCI-3160 board.

The control registers must first be set by software statements to configure each group of A, B, and C ports for the desired direction (input or output) and to prepare interrupt control/status bits.

- For register map A, port directions are set by writing to the combination data and control registers located at BADDR1 + 0x0, BADDR1 + 0x4, BADDR1 + 0x8, and BADDR1 + 0xC (where 0x designates hexadecimal).
- Use of register map B is not recommended or supported. Use only register map A.
- If the board is to transfer and process data upon receipt of external interrupts, the following are set:
 - Bit 12 of the interrupt control/status register, located at BADDR0 + 0x38, is set to 1 to configure the board for interrupt service.
 - The interrupt-pending bit and the interrupt missed bit in BADDR0 are initialized to the cleared condition by writing 1s to interrupt control/status register status bits 17 and 23 at BADDR0 + 38. The polarity select bit is initialized to the clear condition by writing a 0 to the interrupt control/status register control bit 6.

In most applications all eight data bits of each port will be set as either inputs or outputs. However, the upper four bits and lower four bits of port C can be configured separately as either inputs or outputs.

Thereafter, data can be input to or output from the data registers.

- Data ports configured as outputs are set by writing ones and zeros to these registers with software statements.
- Data ports configured as inputs are set by applying logical high and low signals to the input terminals. These set values are retrieved by one of the following methods:
 - The set input values are retrieved via polling or software commands if the KPCI-3106 I/O bits are configured as general-purpose I/O bits (no external interrupt service).
 - The set input values are retrieved and processed via external interrupts if interrupt control/status-register bit 12 is set high. Refer to [Section 4, “External Interrupts,”](#) and to the previous subsection, [“Interrupt control/status register.”](#)
- If you retrieve data using interrupts, the interrupt-pending bit and interrupt-missing bit must be cleared by software at the conclusion of each interrupt-service (ISR) by writing ones (Acknowledge) to interrupt control/status register bits 17 and 23 at base address 0 + 0x38. The interrupt enable bit and interrupt polarity select bit of the interrupt control/status register are cleared by writing zeros to bits 12 and 6.

Using existing port I/O software to manipulate control and data registers

If you have a port I/O application program that was designed to work with the industry-standard 8255 and 82C55 chips, you may be able to reuse it without program modifications—under Windows 95/98 only—as follows:

1. Leave the REG-MAP-SEL jumper unconnected (the default), so that the board operates in the 8255/82C55 emulation mode under control and data register map A.
2. Using the Windows Device Manager, locate the Windows-assigned base address for your board as follows:
 - a. Right-click the **My Computer** icon on your desktop.
 - b. On the menu that appears, click **Properties**.
 - c. On the System Properties dialog box that appears, click the **Device Manager** tab. The Device Manager appears.
 - d. In the Device Manager look for a **DriverLINX drivers** item.
 - e. Under the **DriverLINX drivers** item, click the + sign to the left of this item. A second level list should appear that includes the KPCI-3160 board.
 - f. Select the KPCI-3160 board.
 - g. Click on the **Properties** button. A Keithley KPCI-3160 Board Properties dialog box appears.
 - h. In the Keithley KPCI-3160 Board Properties dialog box click the **Resources** tab. A Resource Settings list appears.
 - i. In the Resource Settings list, two I/O space ranges should appear, each labeled **Input/Output Range**. Record the starting address of the **Input/Output Range** that contains 32 bytes—typically the second of the two **Input/Output Range** ranges. This is the BADDR1 base address. (Refer to [“General PCI address assignments.”](#))

For example, if one **Input/Output Range** is FCC0 - FCFF and the other is FCA0 - FCBF, then FCA0 is the BADDR1 base address, because:

$(FCBF \text{ minus } FCA0)_{\text{hex}} = 1F_{\text{hex}} = 31_{\text{decimal}}$ (32 bytes, counting the base-address byte)

The other **Input/Output Range**, starting at BADDR0, always contains 64 bytes. Following the above example, $(FCFF \text{ minus } FCC0)_{\text{hex}} = 31F_{\text{hex}} = 63_{\text{decimal}}$.

3. In your existing application program, where you are asked to enter the base address of the board, enter the BADDR1 base address that you found in step 2i (in place of the base address that you would have manually assigned to an ISA board using a DIP switch).
4. Run your existing application program in Windows or DOS mode, as appropriate.

If your operating system is Window NT, you need to provide a special driver and probably need to revise your existing port I/O application program before it can manipulate KPCI-3160 port I/O. (You then find the needed PCI BIOS-assigned base address using Windows NT Diagnostics, instead of the Windows 95/98 Device Manager). *Keithley does not recommend or support such efforts.*

C Glossary

Address¹

A number specifying a location in memory where data is stored.

API

See application programming interface.

Application programming interface¹

A set of routines used by an application program to direct the performance of a procedure by the computer's operating system.

Bus mastering

On a microcomputer bus such as the PCI bus, the ability of an expansion board to take control of the bus and transfer data to memory at high speed, independently of the CPU. Replaces direct memory access (DMA).

Bus

An interconnection system that allows each part of a computer to communicate with the other parts.

Byte

A group of eight bits.

Contact bounce

The intermittent and undesired opening of relay contacts during closure, or closing of relay contacts during opening.

Crosstalk

The coupling of a signal from one input to another (or from one channel to another or to the output) by conduction or radiation. Crosstalk is expressed in decibels at a specified load and up to a specific frequency.

Darlington

A high gain current amplifier composed of two bipolar transistors, typically integrated in a single package.

DLL

See Dynamic Link Library.

Direct memory access

See DMA mode.

DMA mode

Direct memory access mode. Mode in which data transfers directly between an I/O device and computer memory. In the most general sense, PCI bus mastering is a DMA mode. More commonly, however, DMA mode refers to data transfers across the ISA bus, using a special circuitry on the computer motherboard. *See also* bus mastering.

Driver

Software that controls a specific hardware device, such as a data acquisition board.

Dynamic Link Library (DLL)

A software module in Microsoft Windows containing executable code and data that can be called or used by Windows applications or other DLLs. DLL functions and data are loaded and linked at run time when they are referenced by a Windows application or other DLLs.

Expansion slot¹

A socket in a computer designed to hold expansion boards and connect them to the system bus (data pathway).

Foreground task

An operation, such as a task that occurs in the single or synchronous mode, that cannot take place while another program or routine is running.

FIFO

First-in/first-out memory buffer. The first data into the buffer is the first data out of the buffer.

GPIB

Abbreviation for General Purpose Interface Bus. It is a standard for parallel interfaces.

IEEE-488

See GPIB.

Input/Output (I/O)

The process of transferring data to and from a computer-controlled system using its communication channels, operator interface devices, data acquisition devices, or control interfaces.

Input/output port¹

A channel through which data is transferred between an input or output device and the processor.

ISA Bus

Industry Standard Architecture. The 16-bit wide bus architecture used in most MS-DOS and Windows computers. Sometimes called the AT bus.

Map¹

Any representation of the structure of an object. For example, a memory map describes the layout of objects in an area of memory, and a symbol map lists the association between symbol names and memory addresses in a program.

OCX

Abbreviation for OLE Custom Control.

Pass-through operation

See target mode.

PCI

Abbreviation for Peripheral Component Interconnect. It is a standard for a local bus.

Port

See input/output port.

Port group

For digital I/O emulating the I/O of an 8255 programmable peripheral interface chip, a group of three 8-bit ports, commonly labeled PA, PB and PC. Digital I/O that emulates multiple 8255 chips is typically divided into multiple port groups.

Port I/O call

A software program statement that assigns bit values to an I/O port or retrieves bit values from an I/O port. Examples include a C/C++ statement containing an `inp` or `outp` function or a Basic statement containing a `peek` or `poke` function.

Register¹

A set of bits of high speed memory within a microprocessor or other electronic device, used to hold data for a particular purpose.

Shielding

A metal enclosure for the circuit being measured or a metal sleeve surrounding wire conductors (coax or triax cable) to lessen interference, interaction, or current leakage. The shield is usually grounded.

Target mode

A PCI bus mode in which data from a data acquisition board is transferred indirectly to the computer memory in the foreground, via the host computer CPU, instead of directly, via Bus mastering. Sometimes referred to as pass-through operation. *See also* bus mastering and foreground task.

Trap¹ (verb)

To intercept an action or event before it occurs, usually in order to do something else.

TTL

Abbreviation for transistor-transistor-logic. A popular logic circuit family that uses multiple-emitter transistors. A low signal state is defined as a signal 0.8V and below. A high signal state is defined as a signal +2.0V and above.

¹*Microsoft Press® Computer Dictionary, Third Edition.* Refer to “Sources” below.

Sources:

Keithley Instruments, Inc., *Catalog and Reference Guide* (full line catalog), glossary, 1998

Microsoft Press® Computer Dictionary, Third Edition (ISBN: 1-57231-446-X) by Microsoft Press. Reproduced by permission of Microsoft Press. All rights reserved.

Index

A

- Accessories. *See also* individual product numbers 3-16
- Address
 - base B-3
 - base, assignment B-3
 - definition C-2
- Addresses
 - data and control registers B-4
 - Interrupt control/status register B-5
 - PCI general assignments B-2
- ADP-5037 accessory 3-16
- AIO Panel
 - example 5-16
 - starting 5-16, 5-23
 - using, in bit tests 5-16, 5-23
- AMCC S5933 bus controller B-8
- AND gate, in debounce circuit 3-17
- API
 - definition C-2
- Application program
 - ISA card port I/O call, using with KPCI-3160 B-8
 - TestPoint or LabVIEW 2-3, 3-2
- Application programming interface
 - definition C-2
- Applications for board, examples 2-2

B

- Bad board
 - checking for 5-3, 5-4
- Base address B-3
 - assignment B-3
- Bits
 - register, assignments B-3
- Board
 - bad, checking for 5-3, 5-4
 - grounding during handling to protect 3-4
 - handling 3-4, 3-10
 - PCI resource, checking for 5-11
 - returning to Keithley 5-26
 - spare, using in troubleshooting 5-3, 5-4
 - unwrapping and inspecting 3-5

- Boards, multiple
 - problems, checking for 5-3, 5-4
- Bus
 - definition C-2
 - memory assignments B-2
- Bus controller, AMCC S5933 B-2, B-8
- Bus mastering B-3
 - definition C-2
- Byte
 - definition C-2

C

- CAB-1800 accessory 3-16
- CAB-1800/S accessory 3-16
- Cables
 - locally made, connector for 3-10
 - manufactured 3-15
- CACC-2000 accessory 3-16
- Checking
 - board + DriverLINX installation 3-6
 - resources 3-5
- Common, digital. *See* grounding, signal, I/O pin assignment
- Computer requirements. *See* system requirements
- Configuring board + DriverLINX installation 3-6
- CONN-3160-D1 accessory
 - connector pin correspondence 3-11, 3-13, 3-14, 3-15
 - description 3-10
 - KPCI-3160 accessories connectable through 3-16
- Connection points, locating and identifying 3-8
- Connections
 - accessories 3-10
 - cables 3-10
 - external circuits 3-17
 - external, checking during troubleshooting 5-3, 5-4
 - pin assignments, I/O connectors 3-8
 - to external circuits 3-17
 - using I/O conditioning 3-17
 - using interface accessories 3-10
 - using pullups 3-17

- Connector
 - expansion slot, troubleshooting 5-3, 5-4
 - I/O, mating, type to use 3-8, 5-14, 5-22
 - KPCI-3160 I/O
 - pin assignments 3-8
 - pin descriptions 3-9
- Connectors
 - board locations 3-9
 - CONN-3160-D1, pin correspondence 3-11, 3-13, 3-14, 3-15
- Connectors, I/O
 - port group assignments 3-10
- Contact bounce
 - definition C-2
 - elimination, circuit 3-17
- Contacts
 - bounce elimination 3-17
 - monitoring closure 3-17
- Control register
 - assignments B-3
 - bit functions B-4
- Conventions, font/typeface 1-2
- Cross references, using in electronic manual
 - moving from the point of reference to the referenced text 1-3
 - returning from the referenced text to the point of reference 1-3
- Crosstalk
 - definition C-2
- Current
 - output, capacity 2-3
- Current, I/O rating 2-3

D

- Darlington
 - definition C-2
- Data register assignments B-3
- Delphi
 - DriverLINX driver for 3-2, B-2
- Digital common. *See* grounding, signal, I/O pin assignment
- Direct I/O. *See* ports, configuration, direct
- Direct Memory Access
 - definition C-2
- Division, PC ports 2-3
- DMA mode
 - definition C-2
- Driver
 - definition C-2
 - for board. *See* DriverLINX
 - programming language support. *See* programming languages
 - writing your own B-8

- DriverLINX
 - AIO Panel. *See* AIO Panel
 - description 3-2
 - installing 3-3
 - DriverLINX software 3-2
 - Dynamic Link Library (DLL)
 - definition C-2

E

- Emulation, 8255 chip 2-2
- ERA-01 accessory 3-16
- ERB-24 accessory 3-16
- Expansion Slot
 - definition C-2
- Expansion slot
 - connector problems, checking for 5-4
 - requirement 2-2

F

- FIFO
 - definition C-3
- Flowchart, troubleshooting 5-4
- Font conventions 1-2
- Foreground task
 - definition C-3

G

- GPIB
 - definition C-3
- Grounding
 - handling to protect board 3-4
 - signal, I/O pin assignment 3-8
 - to protect board 3-4, 3-10

H

- Help, getting Keithley. *See* technical support

I

- I/O
 - 8255 PPI chip emulation 2-2
 - current capability 2-3
 - Emulation, chip 2-2
- I/O bits
 - board capacity 2-2
 - configuring and setting
 - AIO Panel, using, examples. *See* I/O bit tests
 - DriverLINX. *See* your DriverLINX manuals
 - testing, loop-back test 5-13
 - testing, output set tests 5-22

- I/O connector
 - mating, type to use 3-8, 5-3, 5-14
- I/O space mapping. *See* registers
- IEEE-488
 - definition C-3
- Input/Output (I/O)
 - definition C-3
- Input/output port
 - definition C-3
- Inspecting board 3-5
- Installation
 - accessories 3-10
 - cables 3-10
 - checking 3-6
 - configuration 3-6
 - DriverLINX 3-3
 - external circuits 3-17
- INT_ENN (external interrupt enable) 4-2
 - connector pin assignment 4-2
- INT_REQ (external interrupt request) 4-2
 - connector pin assignment 4-2
 - edge trigger options
 - control/status bits B-5
 - description 4-2
- Interrupt, external
 - connector pins configurable for 4-2
 - INT_ENN input 4-2
 - INT_REQ input 4-2
 - use of 4-3, B-6
- Interrupt-missed bit 4-3
- Interrupt-pending bit 4-3
- ISA Bus
 - definition C-3

L

- LabVIEW
 - installation 3-4
- LabVIEW software 3-3
- Logic levels
 - checking, using DMM or DVM 5-22
- Loop-back test 5-13
 - selecting connector to connect to 5-15

M

- Map
 - definition C-3
- Mapping, memory (I/O space) B-2
- Mating connector, I/O. *See* connector, I/O, mating, type to use
- Memory
 - control and data register setting B-8

- Mode
 - control register 2-2
- Moving around manual, electronic
 - cross references, using
 - moving from the point of reference to the referenced text 1-3
 - returning from the referenced text to the point of reference 1-3
 - general 1-3
- Multiple boards
 - problems, checking for 5-3, 5-4

O

- OCX
 - definition C-3
- OS requirements. *See* operating system, required
- Output set test
 - procedure 5-22
 - selecting I/O connector to connect to 5-22

P

- Passthrough operation B-2
- PCI
 - bus. *See* bus
 - definition C-3
 - resource, checking for board as 5-3, 5-4
 - slot. *See* expansion slot
- PCI resource
 - checking for board as 5-11
- Plug and Play B-3
- Port group
 - assignments 3-8, 3-9, B-2
 - assignments, register map B-4
 - control register bit functions B-4, B-5
 - definition C-3
- Port I/O call
 - definition C-3
- Port I/O. *See* ports, configuration, direct
- Ports
 - configuration, direct B-2, B-8, B-9
 - configuration, on power-up/reset 2-3
 - configuration, PIO Control Panel. *See* PIO Control Panel, using, in bit tests
 - PC, division 2-3
 - read/write access 2-3
 - width 2-2
- Power
 - 5 VDC for external circuits 3-18
- Power, board
 - circuits, for external 3-18
- Power-up/reset configuration, ports 2-3

- Precautions
 - base address, different meaning [B-3](#)
 - board, power OFF when servicing. *See* board handling
 - board, unwrapping and handling. *See* board handling
 - external interrupt limitations [4-3](#)
 - installation
 - board [3-4](#)
 - DriverLINX before board [3-5](#)
 - installing DriverLINX before board [3-2](#)
 - installing DriverLINX before TestPoint or LabVIEW [3-3](#)
 - register level programming [B-2](#)
 - testing, multiple boards [5-5](#)
 - using board power [3-18](#)
- Problem isolation
 - flowchart [5-4](#)
 - systematic [5-3](#)
- Problems. *See* troubleshooting
- Program
 - checking during troubleshooting [2-3](#), [5-3](#)
- Program, application
 - ISA card port I/O call, using with KPCI-3160 [B-8](#)
 - TestPoint or LabVIEW [3-2](#)
- Programming
 - register level, avoiding [B-2](#)
 - register level, special situations [B-8](#)
- Programming languages
 - DriverLINX driver for, compatibility [3-2](#), [B-2](#), [B-8](#)
 - DriverLINX driver for, using with other than Visual C/C++, Visual Basic, and Delphi [B-8](#)
- Pullup, circuit [3-17](#)

R

- Read/write access, ports [2-3](#)
- Register
 - definition [C-3](#)
- Register level programming
 - avoiding [B-2](#)
 - special situations [B-8](#)
- Registers
 - control and data registers
 - addressing [B-4](#)
 - bit assignments [B-3](#)
 - control bit functions [B-4](#)
 - control registers
 - bit functions [B-4](#)
 - data and control, addresses [B-2](#)
 - data and control, assignments [B-2](#)
 - interrupt control/status register
 - bit descriptions [B-5](#)
 - example scenario [B-6](#)
 - programming. *See* register level programming
 - setting [B-8](#)

- Repairs, board [5-26](#)
- Resources, checking [3-5](#)
- Returning board [5-26](#)
- Returning board to Keithley [5-26](#)

S

- Shielding
 - definition [C-4](#)
- Signal
 - conditioning, input and output [3-17](#)
- Software
 - checking DriverLINX installation [3-6](#)
 - configuring DriverLINX installation [3-6](#)
 - descriptions [3-2](#)
 - included with board [2-3](#), [3-2](#)
 - installation, DriverLINX [3-2](#), [3-3](#)
 - ISA card port I/O call, using with KPCI-3160 [B-8](#)
 - LabView
 - installation, [3-4](#)
 - options [3-2](#)
 - options synopsis [2-3](#)
 - SRA-01 accessory [3-16](#)
 - SSIO-24 accessory [3-16](#)
 - STA-50 accessory [3-16](#)
 - STP-50 accessory [3-16](#)
 - Symptoms and possible causes [5-2](#)
 - System requirements [2-2](#)
 - Systematic problem isolation [5-3](#)

T

- Target mode [B-2](#)
 - definition [C-4](#)
- Technical support [5-26](#)
- Test
 - loop-back [5-13](#)
 - output set [5-22](#)
 - PCI resource, board as [5-11](#)
- TestPoint software [3-3](#)
- Tests
 - I/O bit, in problem isolation scheme [5-3](#), [5-4](#)
 - I/O bit, procedures [5-12](#)
 - installation, board + DriverLINX [3-6](#)
 - troubleshooting [5-3](#)
- Trap
 - definition [C-4](#)
- Troubleshooting
 - first basic checks [5-2](#)
 - flowchart [5-4](#)
 - symptoms and possible causes [5-2](#)
- TTL
 - definition [C-4](#)
- Typeface conventions [1-2](#)

U

Unwrapping board [3-5](#)

V

Visual Basic

DriverLINX driver for [3-2](#), [B-2](#)

Visual C++

DriverLINX driver for [B-2](#)

Visual C/C++

DriverLINX driver for [3-2](#)

W

Wiring

external circuit. *See* connections

loop-back connector. *See* connections

Wrist strap, to protect board. *See* grounding to protect board

Write/read port configuration. *See* AIO Panel, using in bit tests. *See also* registers

Specifications are subject to change without notice.

All Keithley trademarks and trade names are the property of Keithley Instruments, Inc. All other trademarks and trade names are the property of their respective companies.



Keithley Instruments, Inc.

28775 Aurora Road • Cleveland, Ohio 44139 • 440-248-0400 • Fax: 440-248-6168
1-888-KEITHLEY (534-8453) • www.keithley.com

Sales Offices: BELGIUM:

Bergensesteenweg 709 • B-1600 Sint-Pieters-Leeuw • 02-363 00 40 • Fax: 02/363 00 64

CHINA:

Yuan Chen Xin Building, Room 705 • 12 Yumin Road, Dewai, Madian • Beijing 100029 • 8610-6202-2886 • Fax: 8610-6202-2892

FINLAND:

Tietäjantie 2 • 02130 Espoo • Phone: 09-54 75 08 10 • Fax: 09-25 10 51 00

FRANCE:

3, allée des Garays • 91127 Palaiseau Cédex • 01-64 53 20 20 • Fax: 01-60 11 77 26

GERMANY:

Landsberger Strasse 65 • 82110 Germering • 089/84 93 07-40 • Fax: 089/84 93 07-34

GREAT BRITAIN:

Unit 2 Commerce Park, Brunel Road • Theale • Berkshire RG7 4AB • 0118 929 7500 • Fax: 0118 929 7519

INDIA:

Flat 2B, Willocrissa • 14, Rest House Crescent • Bangalore 560 001 • 91-80-509-1320/21 • Fax: 91-80-509-1322

ITALY:

Viale San Gimignano, 38 • 20146 Milano • 02-48 39 16 01 • Fax: 02-48 30 22 74

JAPAN:

New Pier Takeshiba North Tower 13F • 11-1, Kaigan 1-chome • Minato-ku, Tokyo 105-0022 • 81-3-5733-7555 • Fax: 81-3-5733-7556

KOREA:

2FL., URI Building • 2-14 Yangjae-Dong • Seocho-Gu, Seoul 137-888 • 82-2-574-7778 • Fax: 82-2-574-7838

NETHERLANDS:

Postbus 559 • 4200 AN Gorinchem • 0183-635333 • Fax: 0183-630821

SWEDEN:

c/o Regus Business Centre • Frosundaviks Allé 15, 4tr • 169 70 Solna • 08-509 04 679 • Fax: 08-655 26 10

SWITZERLAND:

Kriesbachstrasse 4 • 8600 Dübendorf • 01-821 94 44 • Fax: 01-820 30 81

TAIWAN:

1FL., 85 Po Ai Street • Hsinchu, Taiwan, R.O.C. • 886-3-572-9077 • Fax: 886-3-572-9031